

ZEXEL

FOREWORD

This service manual has been prepared for the purpose of assisting service personnel in providing efficient and correct service and maintenance of the RBD combined governor for diesel engines. This manual explains governor construction and operation, and procedures for governor disassembly, reassembly and adjustments.

Illustrations, drawings and specifications in this manual are the latest at the time of publication. The right is reserved to make changes in specifications and procedures at any time without notice.



FEATURES

Governors for diesel engines are generally classified as follows:

Mechanical governor

This type of governor controls fuel injection quantity using the centrifugal force of fly-weights.

Pneumatic governor

This type of governor controls fuel injection quantity by exerting negative pressure on the intake manifold.

The RBD combined governor is a combination of a mechanical governor and a pneumatic governor, and consequently possesses the merits of both.

The pneumatic governor, although of simple construction, successfully controls fuel injection when the engine speed is low. However, when the engine speed is high, droop (*) becomes greater than that of the mechanical governor since the density of air passing through the intake manifold and the resistance of the air path will vary. (See Fig. 1.)

$$*: \frac{N_2 - N_1}{N_1} \times 100 (\%)$$



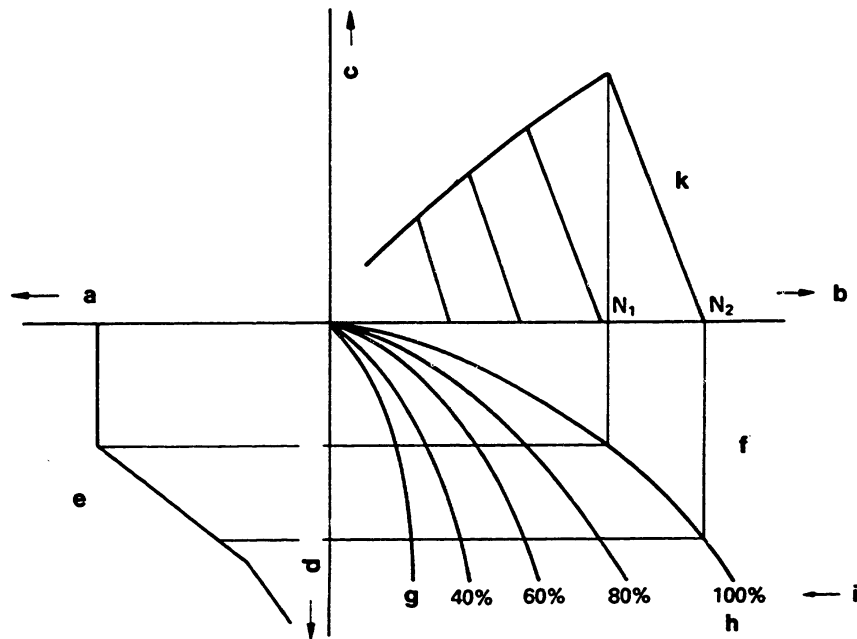

Fig. 1

a = Control rack position (mm)
 b = Engine speed (rpm)
 c = Engine output (ps)
 d = Negative pressure (mmAq)
 e = Governor characteristics

f = Relationship between vacuum and engine speed
 g = Idling
 h = Wide open
 i = Throttle valve position
 k = Engine output characteristics

A3

Features

RBD governor



A4

Features

RBD governor



The mechanical governor successfully controls fuel injection when the engine speed is high. However, its control ability becomes less than that of the pneumatic governor at low speed since the centrifugal force of the flyweights is relatively low.

The RBD combined governor does not suffer from this shortcoming.

The RBD control is such that its mechanical-pneumatic combination can be fully utilized: in the low- and middle-speed ranges a pneumatic governor is actuated; whereas maximum speed is controlled through the actuation of a mechanical governor. (Fig. 2)

A5

Features

RBD governor



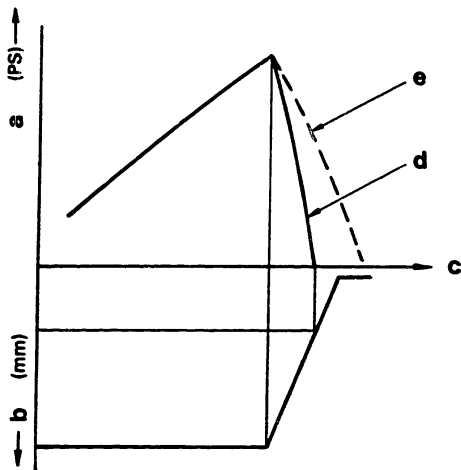

Fig. 2 Relationship between governor characteristics and engine output characteristics

- a = Engine output
- b = Control rack position
- c = Engine speed (rpm)
- d = Mechanical governor control
- e = Pneumatic governor control only



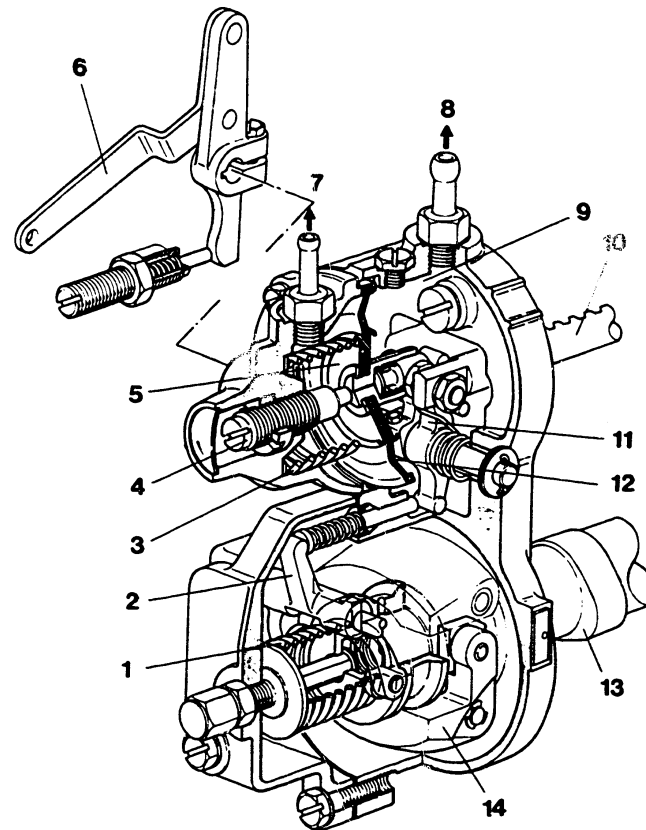

Fig. 3 MZ type

CONSTRUCTION

- 1 = Governor spring (2)
- 2 = Guide arm
- 3 = Governor spring (1)
- 4 = Idling spring capsule
- 5 = Negative pressure chamber
- 6 = Control lever
- 7 = Intake manifold

- 8 = Throttle valve
- 9 = Atmospheric pressure chamber
- 10 = Control rack
- 11 = Full-speed lever
- 12 = Diaphragm
- 13 = Camshaft
- 14 = Flyweight assembly

A7	Construction	➔
	RBD governor	

A8	Construction	↔
	RBD governor	

The control rack is connected to the diaphragm sub-assembly with a connecting bolt.

The torque control spring and rod are built into the diaphragm sub-assembly. The atmospheric pressure chamber is separated from the negative pressure chamber by the diaphragm.

The governor spring (1), incorporated in the negative pressure chamber, pushes the control rack in the "fuel-increase" direction via the diaphragm. The idling-spring capsule is fixed to the negative pressure chamber with a lock nut. In the atmospheric pressure chamber, the full-speed lever is attached to the lever shaft. The upper end of the lever is in contact with the diaphragm rod, while the lower end is pushed against the pushrod by the guide arm when the flyweights open. The middle area on the opposite side is held against the stopping lever pin by a return spring.

The stopping lever, itself adjacent to the full-speed lever, is fixed to the lever shaft by screws.

The lower part of the control lever is fixed against the smoke setscrew. The flyweight assembly is attached to the injection pump camshaft, with the flyweight slider in contact with the governor spring (2) via the sleeve and spring guide.

When the flyweight opens outward the governor spring will be compressed to push the guide arm. (Fig. 3)



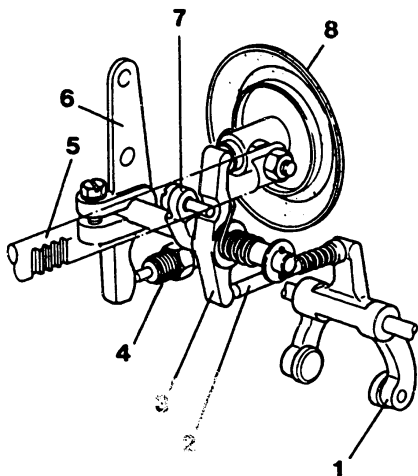

Fig. 4

- 1 = Guide arm**
- 2 = Push rod**
- 3 = Full-speed lever**
- 4 = Smoke setscrew**
- 5 = Control rack**
- 6 = Control lever**
- 7 = Stopping lever**
- 8 = Diaphragm**

The motion of the guide arm is transmitted through the pushrod to the full-speed lever and diaphragm, to move the control rack in the "fuel-decrease" direction. (Fig. 4)



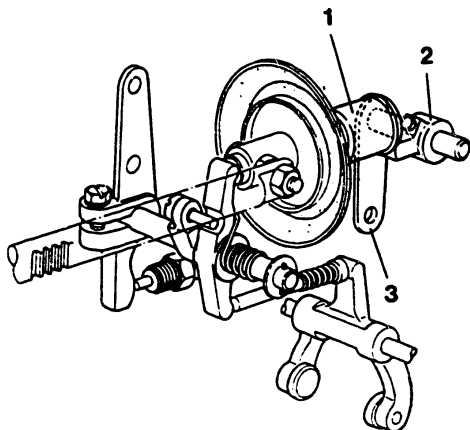

Fig. 5 MN type

- 1 = Idling spring capsule
- 2 = Camshaft
- 3 = Control lever

As well as the MZ-type described above, the combined governor Model RBD also includes another type—the MN type. The MN type is equipped with a camshaft to render the idling spring inactive. (Fig. 5)



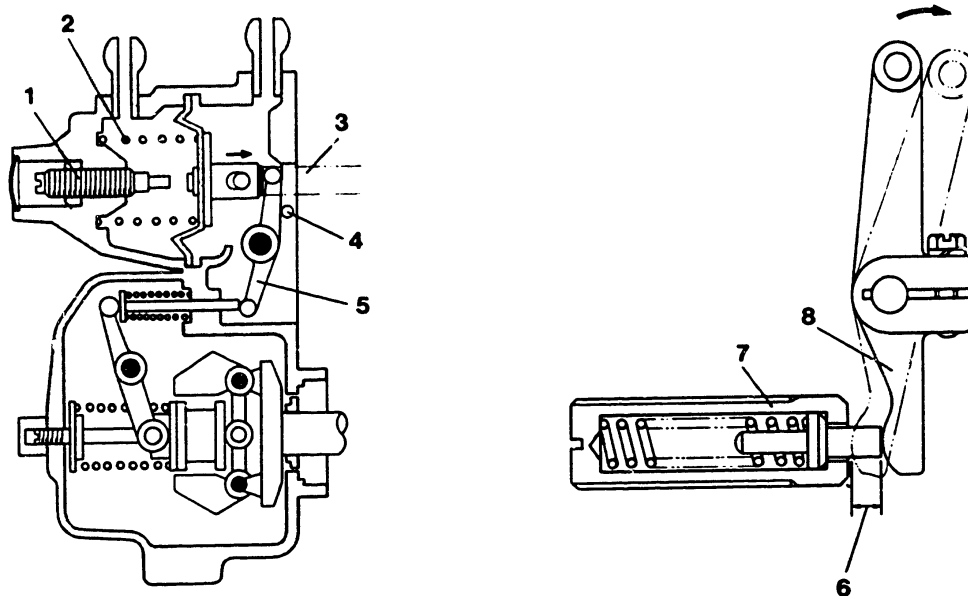

Fig. 6

OPERATION

- 1 = Idling spring capsule
- 2 = Governor spring
- 3 = Control rack
- 4 = Stopping lever
- 5 = Full-speed lever

- 6 = Excessive fuel stroke
- 7 = Smoke setscrew
- 8 = Control lever

Control of Engine Starting

While the engine is stopped the control rack is in the "maximum fuel-injection" position with the diaphragm acted upon by the governor spring.

To facilitate engine starting, an injected fuel quantity greater than the full-load injection quantity is necessary. A powerful spring is built into the smoke setscrew for this purpose.

A12

Operation
RBD governor



A13

Operation
RBD governor



The spring can be compressed by moving the control lever to a horizontal position, whereby the control rack will move in the "fuel-increase" direction through the reaction of the governor spring. (Fig. 6)

Note: This device is not to be used for the purpose of increasing engine output.

A14

Operation

RBD governor



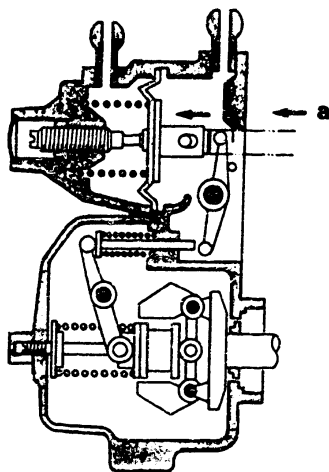

Fig. 7

a = "Fuel decrease" direction

Idling Control

Once the engine starts and the accelerator pedal is released, the throttle valve in the Venturi tube will close almost completely, resulting in decreased pressure in the governor's negative pressure chamber. Thus, the diaphragm compresses the governor spring and in turn the idling spring. Fuel is again injected when the forces of the idling spring and governor spring are balanced against the negative pressure.

Thus, idling speed is constant. (Fig. 7)



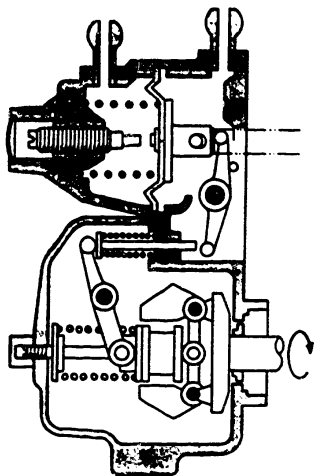

Fig. 8

Normal Operating Conditions

Depressing the accelerator causes the throttle valve in the Venturi tube to open, resulting in increased pressure in the negative pressure chamber.

Therefore, the force of the governor spring exceeds the negative pressure, and the diaphragm is forced in the "fuel-increase" direction to increase engine speed. When the negative pressure balances the force of the governor spring diaphragm movement will cease. Fuel is then injected and a stable engine speed is maintained. (Fig. 8)



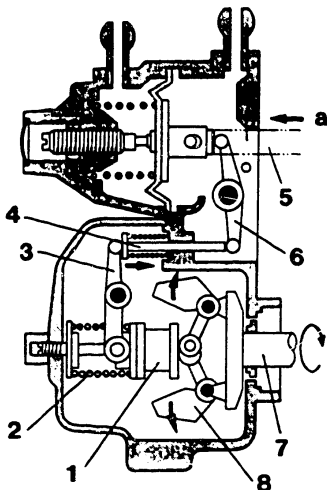

Fig. 9

- 1 = Sleeve
- 2 = Governor spring
- 3 = Guide arm
- 4 = Push rod
- 5 = Control rack
- 6 = Full-speed lever
- 7 = Camshaft
- 8 = Flyweight

a = "Fuel decrease" direction

Maximum Speed Control

Once engine speed reaches the predetermined maximum as a result of a change in the engine load, the centrifugal force of the flyweights balances the preset force of the governor spring.



Maximum Speed Control (continued)

A further increase in engine speed will cause the flyweights to open outward and compress the governor spring via the sleeve. The pushrod, via the guide arm, acts on the lower end of the full-speed lever, moving it to the right.

The upper end of the full-speed lever will then move the diaphragm and control rack in the "fuel-decrease" direction, therefore decreasing engine speed.

Engine speed is therefore controlled such that the specified maximum speed cannot be exceeded. (Fig. 9)

Torque Control Device

The engine's air-intake efficiency has a tendency to decrease with an increase in speed. Conversely, the quantity of injected fuel per stroke will increase with increased speed, even though the control rack position remains the same, as shown in Figure 10. Accordingly, fuel injection quantity will increase with increased speed if the engine is under a full load in the medium speed range, where adequate engine output can be obtained. As a result, another set point B is established with decreased intake air. This leads to poor fuel combustion, and results in the emission of black smoke.

A18

Operation
RBD governor



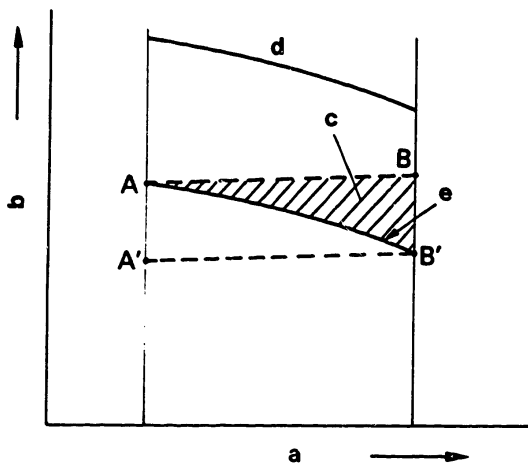

Fig. 10

- a = Engine speed
- b = Injection quantity (per stroke)
- c = Black smoke
- d = Volume of intake air
- e = Fuel requirement curve

Torque Control Device (continued)

If the engine is under a full load at high-speed set point B', the injection quantity at set point A' will be lower than the injection requirement, resulting in inadequate engine torque and output. (See Fig. 10)

The torque control device assures fuel injection follows the fuel requirement characteristic curve, therefore satisfying the conditions for perfect combustion in relation to the engine's air requirement.



The torque control spring is attached to the centre of the diaphragm.

At low speed the torque control spring is completely compressed (stroke=0) against the stopping lever by the force of the governor spring. As pressure decreases with an increase in engine speed, the diaphragm is moved in the "fuel-decrease" direction when atmospheric pressure and the force of the torque control spring exceed the governor spring force, with the torque control spring beginning to expand.

A20

Operation

RBD governor



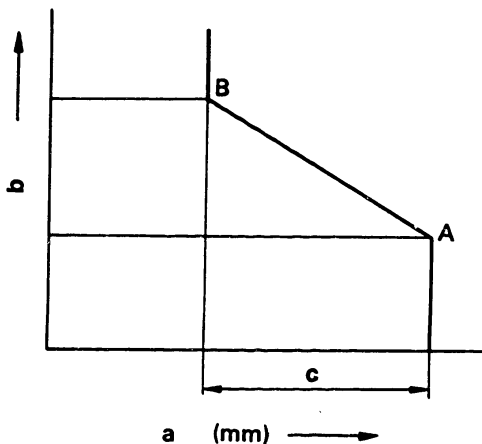

Fig. 11

- a = Control rack position
- b = Negative pressure (mmAq)
- c = Torque control stroke

Set point A in Figure 11 represents the point of equilibrium between the governor spring force, and atmospheric pressure plus the torque control spring force.



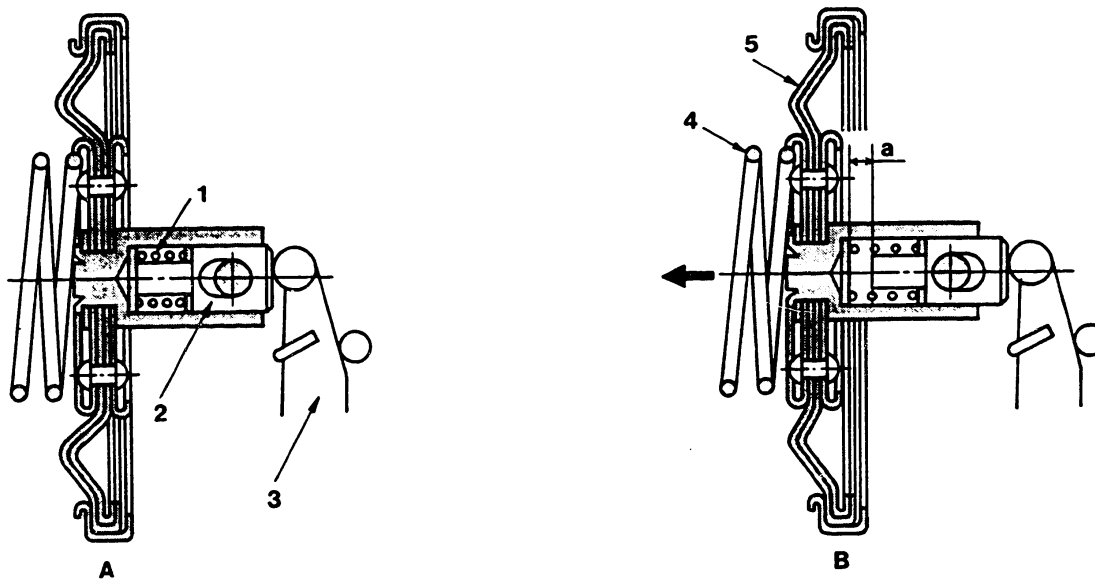

Fig. 12

- 1 = Torque-control spring
- 2 = Rod
- 3 = Full speed lever
- 4 = Governor spring
- 5 = Diaphragm
- a = Torque-control stroke

A decrease in pressure resulting from an increase in engine speed causes the diaphragm to be moved from A in the "fuel-decrease" direction. A further decrease in pressure causes the torque control device to cease functioning at set point B (Figure 11) where the hook connecting bolt comes in contact with the pushrod. (Fig. 11 and 12)

A22	Operation	↔
	RBD governor	

A23	Operation	←
	RBD governor	

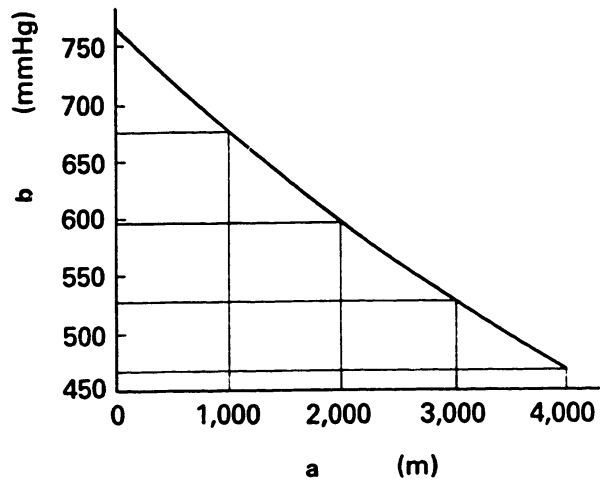

Fig. 13 Relationship between atmospheric pressure and altitude

a = Altitude
b = Atmospheric pressure

ANEROID COMPENSATOR

Fig. 13 shows the relationship between atmospheric pressure and altitude. Atmospheric pressure decreases as altitude increases.

Fig. 14 shows the relationship between atmospheric pressure and air density. Air density decreases as the atmospheric pressure decreases.

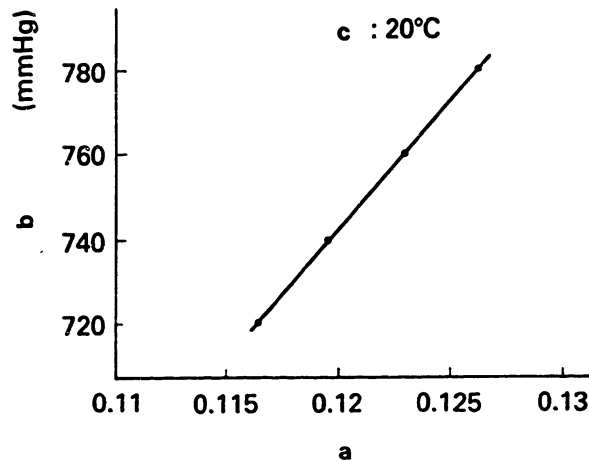

Fig. 14 Dry air density

a = Density (KgS^2/m^4)
b = Atmospheric pressure
c = Air temperature

A24

Aneroid compensator
RBD governor



A25

Aneroid compensator
RBD governor



As mentioned previously, a vehicle with a diesel engine adjusted to function at low altitudes may experience the following problems due to excessive fuel injection when used at high altitudes.

1. Increased emission of black smoke.
2. Insufficient engine output, despite increased fuel consumption.
3. Carbon deposits in the combustion chamber (thus shortening the service life of the engine).

A26

Aneroid compensator

RBD governor



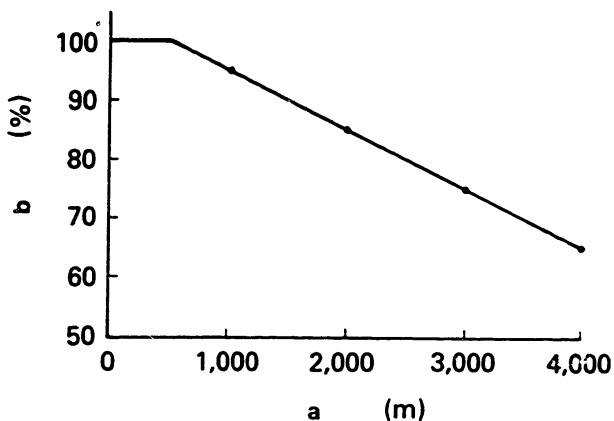

Fig. 15

a = Altitude

b = Full-load injection quantity

In order to prevent the above problems, the full-load fuel injection quantity must be adjusted to compensate for altitude, as shown in Fig. 15.



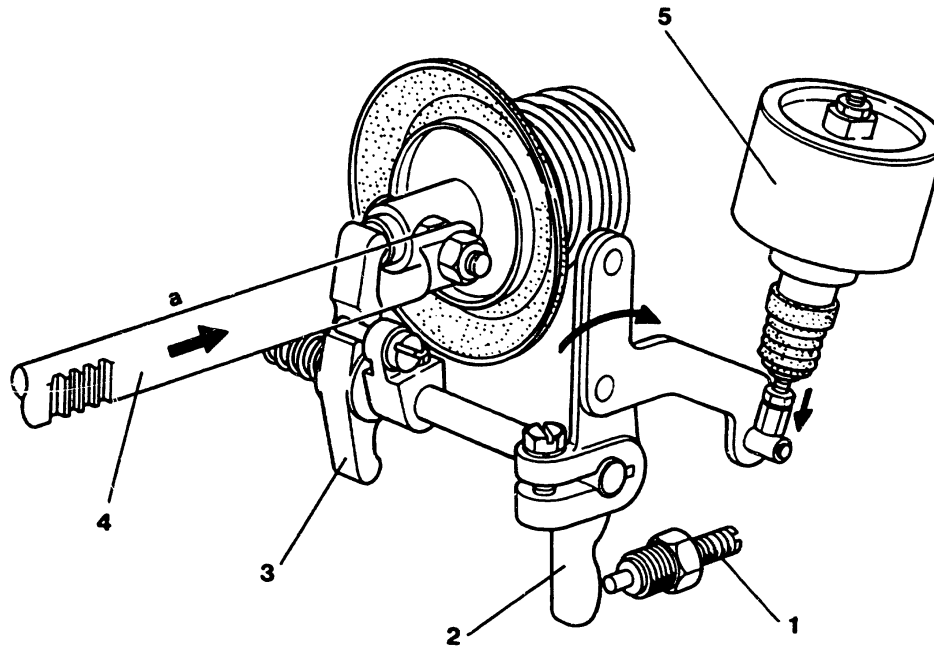

Fig. 16

- 1 = Smoke setscrew
- 2 = Control lever
- 3 = Full-speed lever
- 4 = Control rack
- 5 = Aneroid compensator

a = "Fuel-decrease" direction

The aneroid compensator moves the control lever as the atmospheric pressure changes, allowing the control rack to alter the full-load injection quantity. (See Fig. 16)

B1

Aneroid compensator
RBD governor



B2

Aneroid compensator
RBD governor



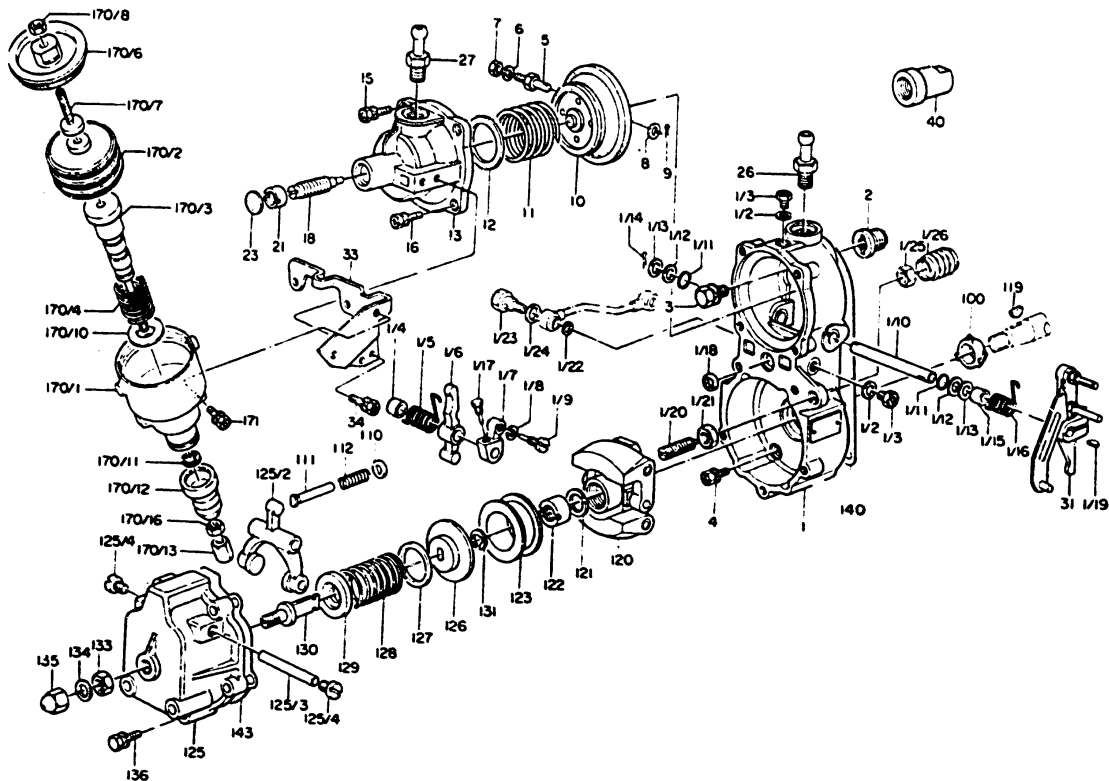

Fig. 17 Exploded view of the aneroid compensator-equipped RBD governor (MZ type)

Construction and Operation

B3

Aneroid compensator
RBD governor



B4

Aneroid compensator
RBD governor



The aneroid compensator, comprising a bellows for maintaining a vacuum, a spring, a push rod, and housing, is attached to the outside of the governor by a bracket (33). The cap (170/13) installed on the pushrod end is in contact with the control lever (31) pin. The smoke setscrew (1/20) controls control lever movement in the "fuel-increase" direction by means of the return spring (1/16).

B5

Aneroid compensator

RBD governor



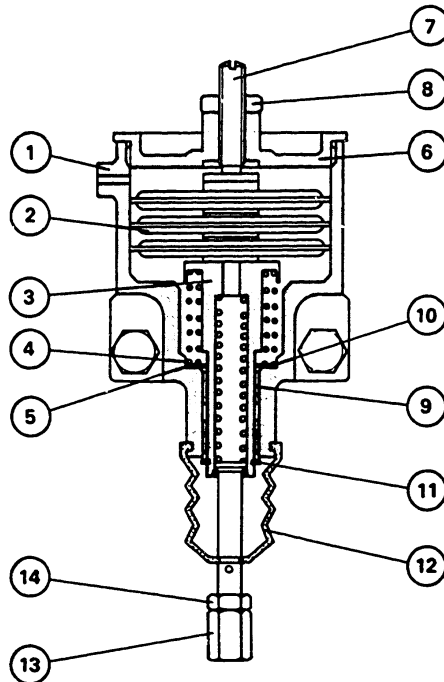

Fig. 18 Aneroid compensator construction

- ① Housing
- ② Bellows
- ③ Sleeve
- ④ Spring
- ⑤ Spring
- ⑥ Cover
- ⑦ Setscrew

- ⑧ Nut
- ⑨ Bushing
- ⑩ Shim
- ⑪ Snap-ring
- ⑫ Rubber boot
- ⑬ Cap
- ⑭ Nut

B6

Aneroid compensator
RBD governor



B7

Aneroid compensator
RBD governor



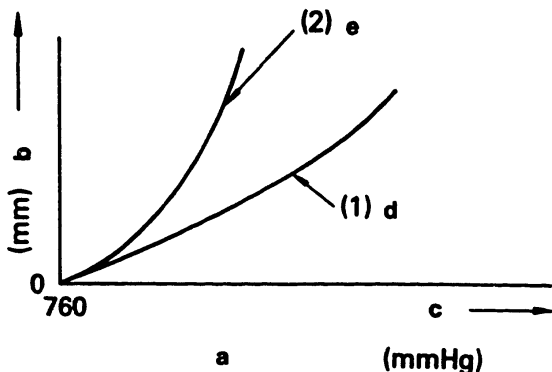

Fig. 19 Relationship between atmospheric pressure and bellows extension

- a = Atmospheric pressure**
- b = Bellows extension**
- c = "Decrease" direction**
- d = (1) without spring force**
- e = (2) Set force applied by spring**

Negative pressure acting on the bellows (2) causes the bellows to extend in an axial direction as shown in Fig. 19.

When the initial set pressure is applied to the bellows through springs (4) and (5), the bellows extension changes from (1) to (2).

It is possible to obtain the required fuel injection quantity necessary for various engines by selecting appropriate springs (4) and (5).



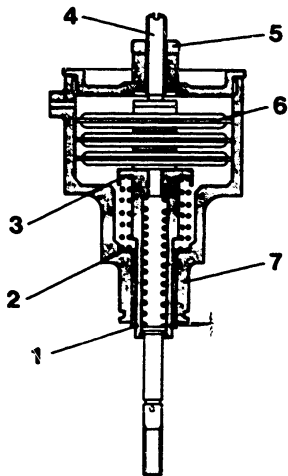

Fig. 20

- 1 = Snap-ring
- 2 = Spring
- 3 = Spring
- 4 = Setscrew
- 5 = Lock nut
- 6 = Bellows
- 7 = Housing

The sleeve (3) is incorporated into the housing (1) by the bushing (9), so that bellows extension can be transmitted to the control lever (31) (shown in Fig. 17) through the pushrod and cap (13). The bellows and springs (4) and (5) are adjusted by the setscrew (7), so that the distance between the housing (1) and snap-ring (11) (see Fig. 20) at sea level is as specified. (refer to Service Data).



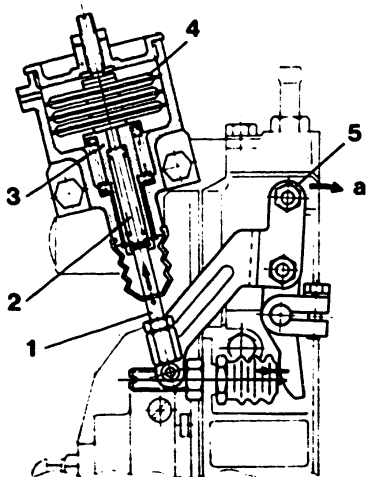

Fig. 21

1 = Push rod
 2 = Spring
 3 = Sleeve

4 = Bellows
 5 = Control lever
 a = "Fuel increase" direction

As a result, the bellows extension characteristics shown in Fig. 19 are obtained, enabling control of fuel injection as shown in Fig. 15. The spring in the sleeve (3) is compressed by the pushrod when the control lever (31) is moved in the "fuel increase" direction at engine starting. (see Fig. 21). Control lever operation is therefore possible without excess force being applied to the bellows.



DISASSEMBLY

Preparation

1. Keep the bench and workshop clean.
2. Before disassembly clean completely the outside surface of the governor and injection pump.
3. Before disassembly record the locking pitches of the adjusting bolts and governor performance to facilitate governor adjustment.

Note: The figures parenthesized at the end of the description of each component refer to part nos. and key nos. given in Fig. 17.



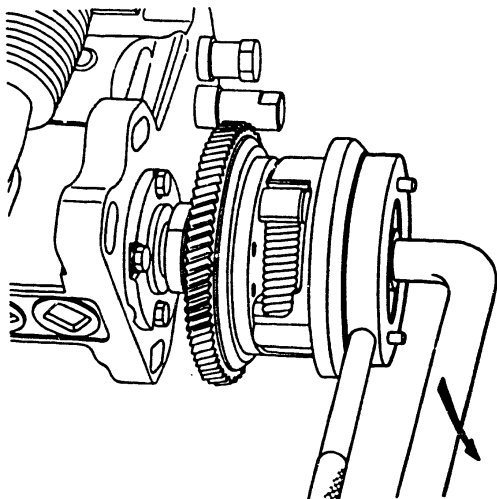

Fig. 22 Removing the round nut

Pneumatic Governor

1. Fix the timing device with a wrench, then remove the round nut (SW 14 mm). (Fig. 22)

B12

Disassembly
RBD governor



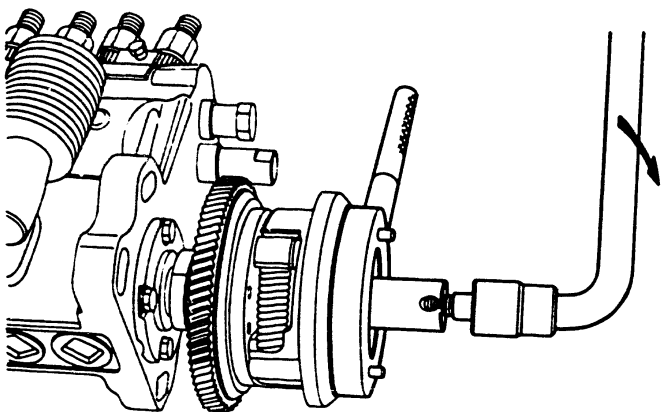
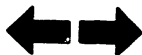

Fig. 23 Removing the timing device

2. Using an extractor (KDEP 2872) remove the timing device.

B13

Disassembly
RBD governor



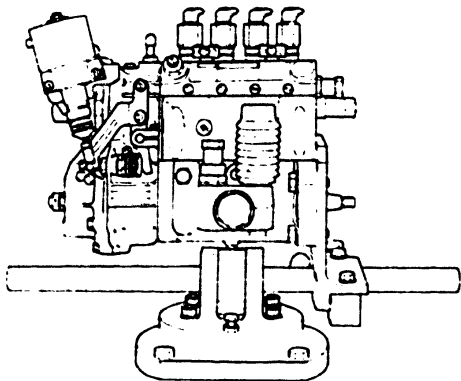
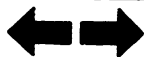

Fig. 24 Attaching the injection pump

- 3. Attach the injection pump to the universal vise.**



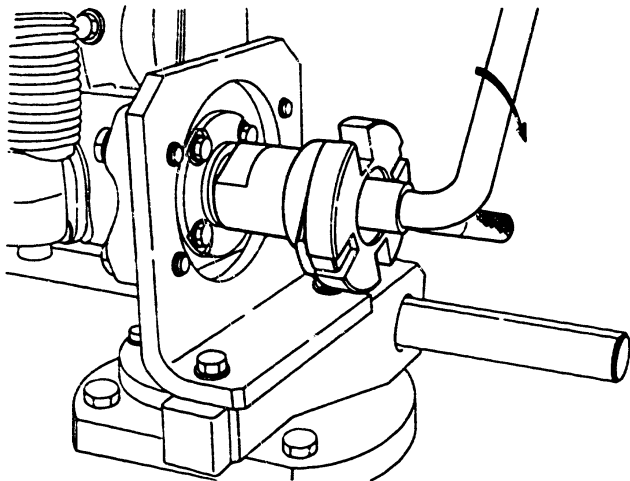

Fig. 25 Attaching the coupling

- 4. Attach the coupling (1 686 430 022) to the camshaft.**

B15

Disassembly
RBD governor



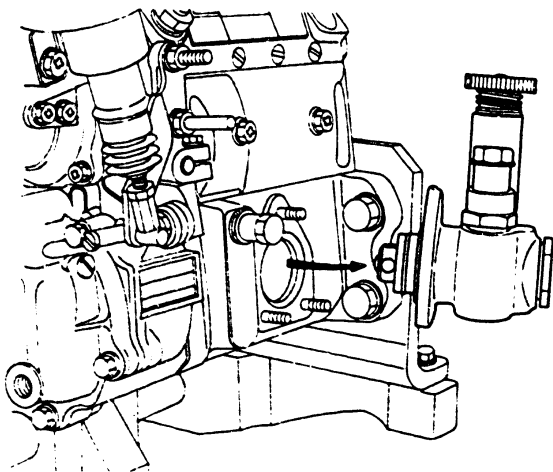

Fig. 26 Removing the supply pump

5. Remove the supply pump.



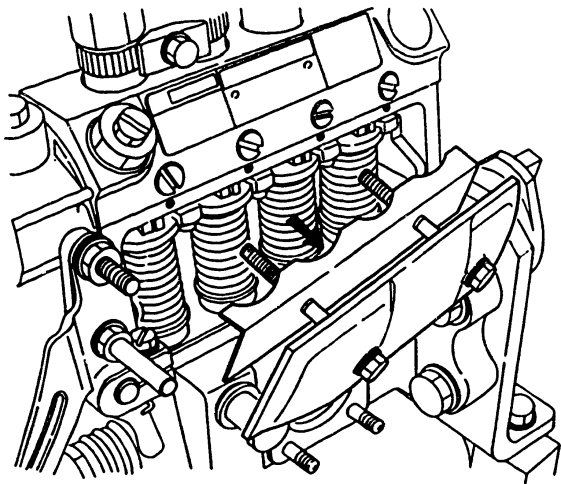

Fig. 27 Removing the cover plate

6. Remove the cover plate.

B17

Disassembly
RBD governor



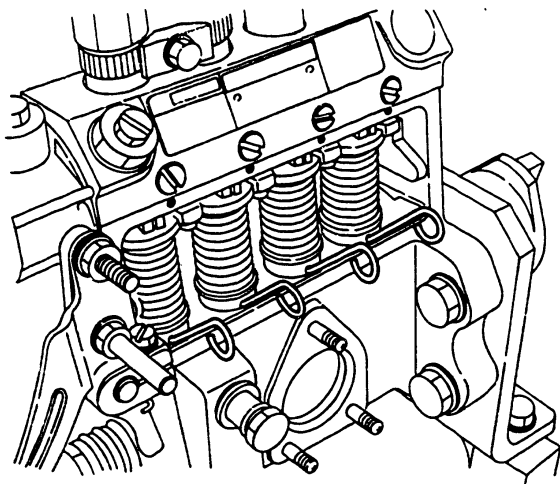

Fig. 28 Inserting the tappet holder

7. Rotate the camshaft until tappet is raised to T.D.C. for each cylinder and then insert the tappet holder (KDEP 2608) into the tappet's hole.



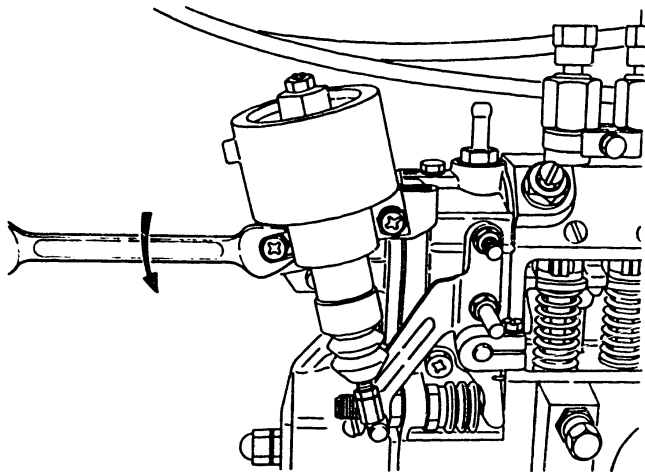

Fig. 29 Removing the two bolts securing aneroïd compensator

8. Remove the two bolts (171) and the aneroïd compensator assembly (170).

Note: This applies only to aneroïd compensator-equipped RBD governor.



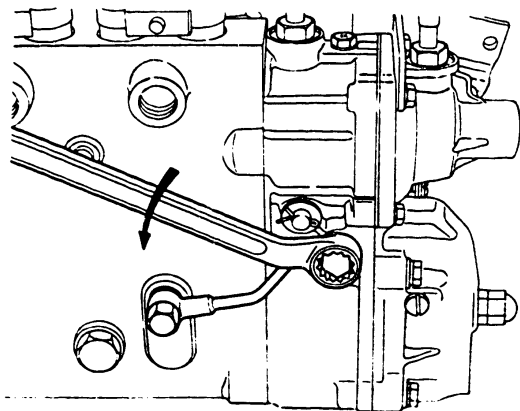

Fig. 30 Removing the oil drain plug

9. Remove the oil drain plug (1/23) and two gaskets (1/22 and 1/24). (Fig. 30)
10. Remove the eyebolt from the injection pump housing, then remove the oil drain pipe.



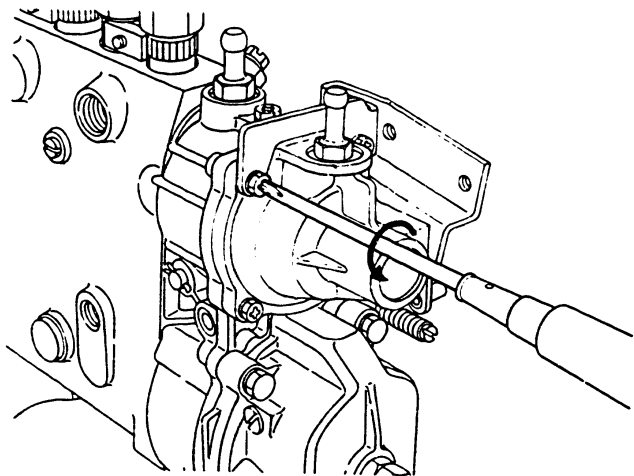

Fig. 31 Removing the four cover bolts

11. Remove the four bolts (15 and 16) and bracket (33), then remove the diaphragm cover (13), governor spring (11) and shims (12) together.



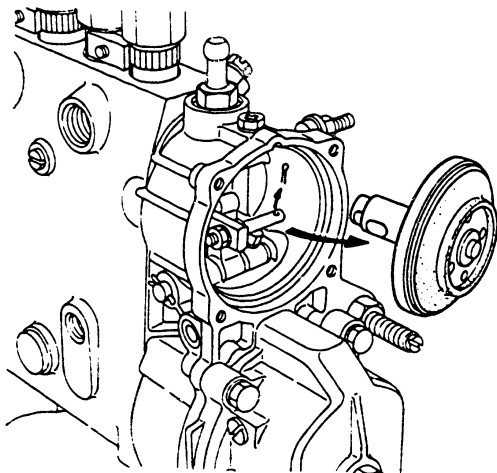

Fig. 32 Removing the diaphragm assembly

12. Remove splitpin (9) from connecting bolt (5) and then remove diaphragm assembly (10). (Fig. 32)

Note: Be careful not to damage the diaphragm, or lose the torque control spring, rod, and shims in the diaphragm joints.



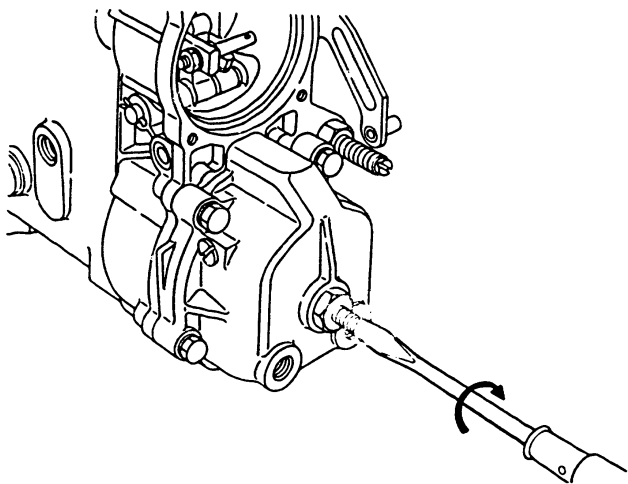

Fig. 33 Governor spring compression

Mechanical governor

1. Remove the cap (135) and gasket (134), and loosen the locknut (133).
2. Fully compress the governor spring (128) by turning the adjusting bolt (130). (Fig. 33)

Note: The direction of the adjusting bolt (130) thread depends on the rotational direction of the injection pump:



Injection pump	Adjusting bolt
CW (from drive side)	Right-hand thread
CCW (from drive side)	Left-hand thread

B24

Disassembly

RBD governor



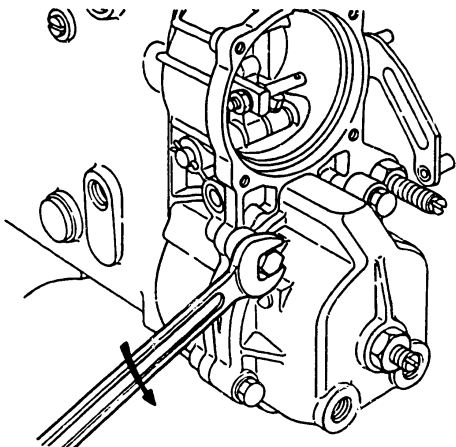

Fig. 34 Removing the five governor cover bolts

3. Remove the five bolts (136) and governor cover (125). (Fig. 34)
4. Remove the sleeve (123), pushrod (111), spring (112) and washer (110).



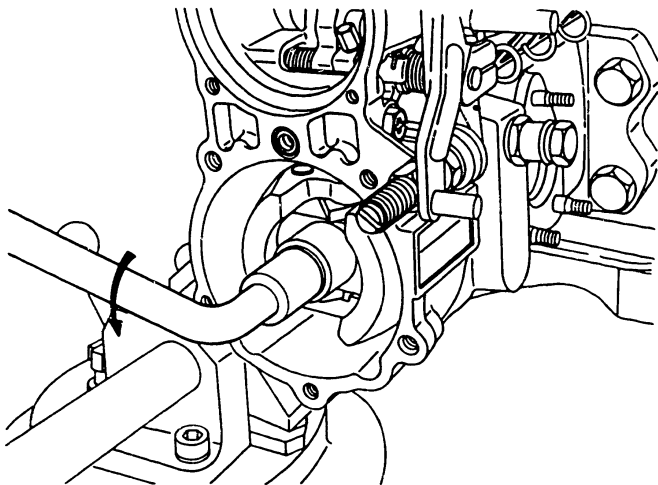

Fig. 35 Removing the locknut

5. Using the special wrench (KDEP 2906), hold the coupling (1 686 430 022) so that the camshaft will not turn.
6. Then, using the wrench (KDEP 2626) and L-bar handle (commercially available), remove the locknut (122) and spring washer (121) together. (Fig. 35)



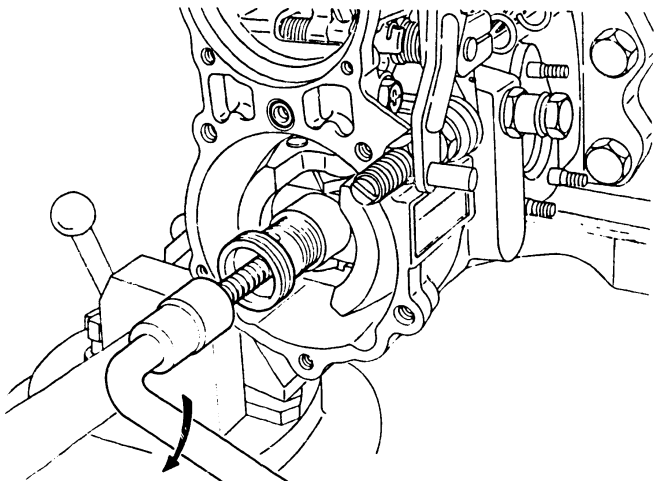

Fig. 36 Removing the flyweight assembly

7. Remove the flyweight assembly using the extractor (KDEP 2918).



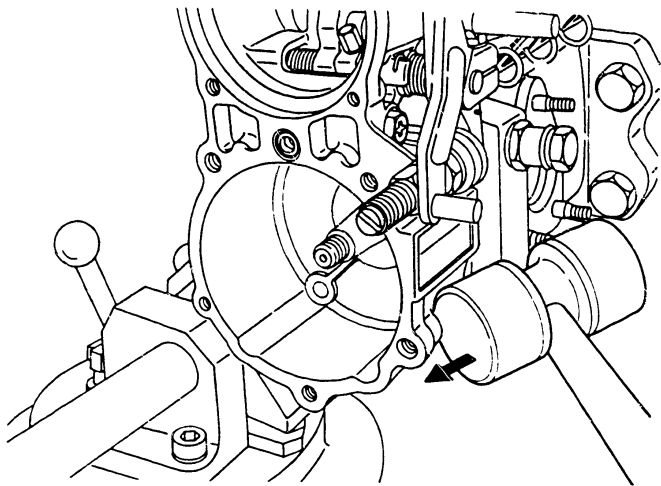

Fig. 37 Governor housing removal

8. Using a philip's head screwdriver and wrench (12 mm), remove the five bolts (3 and 4).
9. By tapping the governor housing (1) lightly with a mallet, separate it from the pump housing. (Fig. 37)



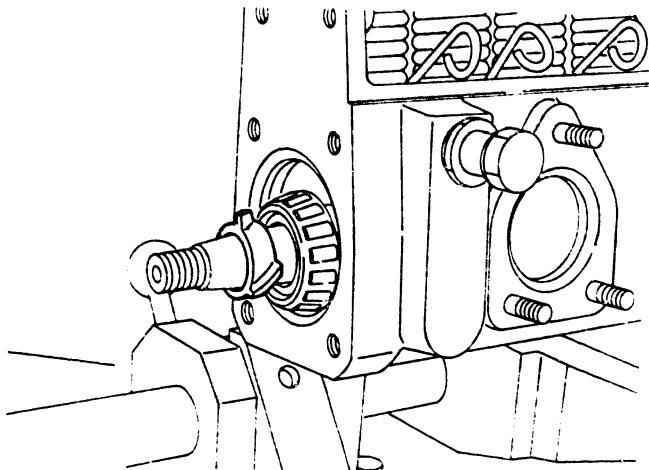

Fig. 38 Removing the impeller

10. Remove the impeller (100) from the camshaft.

C1

Disassembly
RBD governor



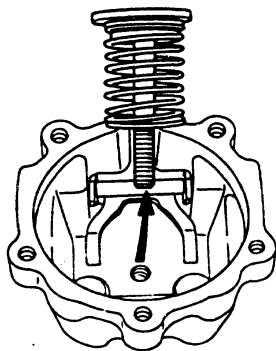

Fig. 39 Adjusting bolt and governor spring removal

The following procedure describes removal of the internal parts of the governor cover.

11. Remove the locknut (133).
12. Remove adjusting bolt (130) to which spring seats (126 and 129), shim (127), and governor spring (128) are fixed via snapping (131). (Fig. 39)



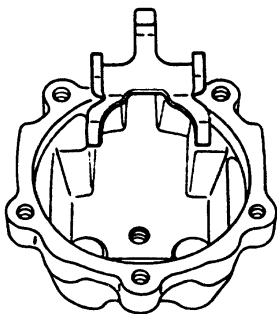

Fig. 40 Removing the guide arm

13. Remove the two plugs (125/4) and then remove the shaft (125/3) and the guide arm.



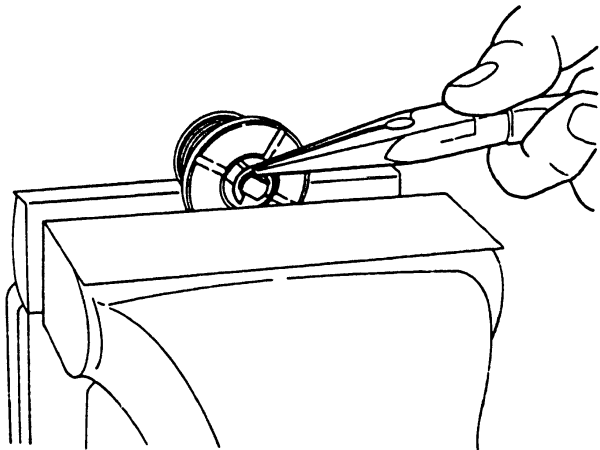

Fig. 41 Removing the snap-ring

14. Remove the governor spring from the adjusting bolt as follows:
 - 1. As shown in Figure 41, grip the two spring seats in a vise.
 - 2. Compress the governor spring.
 - 3. Remove the snap-ring.
 - 4. Remove the governor spring

Note: Be careful that other parts do not spring out with the governor spring when loosening the vise.



INSPECTION

Check each component for wear, damage, rust, or other abnormalities. If any abnormality is detected repair or replace the defective component.

Always replace O-rings and gaskets, even if they appear undamaged.

C5

Inspection

RBD governor



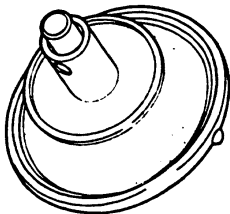

Fig. 42 Inspecting the diaphragm

Diaphragm

Replace the diaphragm if the leather is damaged; even the smallest hole in the diaphragm can adversely affect governor performance. (Fig. 42)

Perform a final inspection of the diaphragm after the air-tightness test.



Springs

Replace any damaged springs i.e. bent, settled, etc., flawed or rusted.

Diaphragm housing

Replace only components where the clearances of the bushes press-fitted into the diaphragm housing have increased due to wear.

C7

Inspection

RBD governor



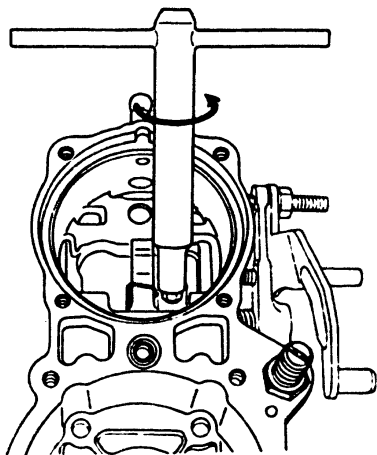

Fig. 43 Removing the screw

Stopping-lever shaft

Remove the stopping-lever shaft as follows:

1. Using a wrench (SW 7 mm) remove the screw (1/17) securing the stopping-lever. (Fig. 43)
2. After loosening the bolt (SW 10 mm) remove the control lever together with the return spring.
3. Remove the bushing (1/15), washers (12 and 13), and O-ring (1/11).



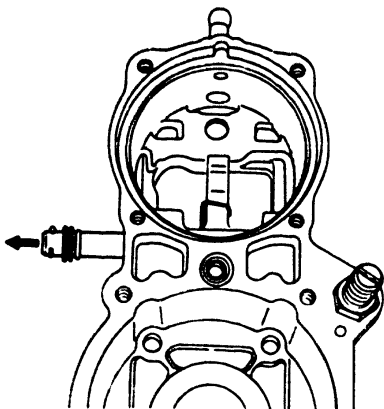

Fig. 44 Removing the stopping-lever shaft

4. By tapping the stopping-lever shaft end (control-lever side) lightly with a mallet, remove it from the diaphragm housing. (Fig. 44)
5. Remove the stopping-lever, full-speed lever (1/16), bushing (1/4) and return spring (1/5).
6. Replace all defective parts. Reassembly of the stopping-lever shaft is the reverse of disassembly.



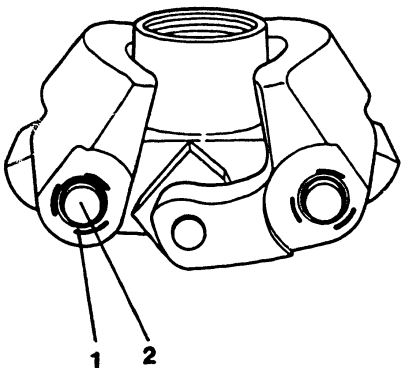

Fig. 45 Flyweight pin section

- 1 = Bushing**
- 2 = Flyweight pin**

Flyweight assembly

- 1. When the clearance between the flyweight pin and the bushing is excessive due to wear, replace the flyweight assembly. (Fig. 45)**



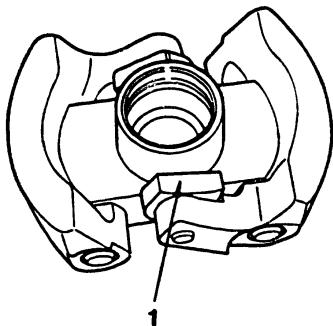

Fig. 46 Check slider for wear

1 = Slider

2. When the contact surface of the slider is worn excessively or the clearance between slider and pin is excessive, replace flyweight assembly. (Fig. 46)

C11

Inspection
RBD governor



REASSEMBLY

Reassembly of the RBD type governor is the reverse of disassembly.

Points requiring special precautions during reassembly are explained below.

G12

Reassembly
RBD governor



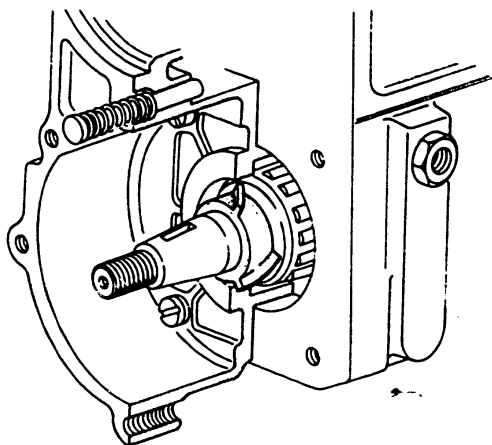

Fig. 47 Attaching the impeller

Impeller

1. After mounting the governor housing, attach the impeller to the camshaft with the flat side of the blades facing the governor. (Fig. 47)



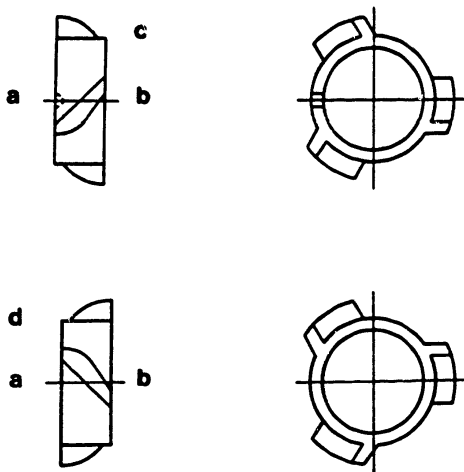

Fig. 48

- a = Governor side**
- b = Pump side**
- c = Clockwise rotation**
- d = Counterclockwise rotation**

2. The impeller's blade orientation depends on the direction of rotation of the injection pump, as shown in Figure 48.



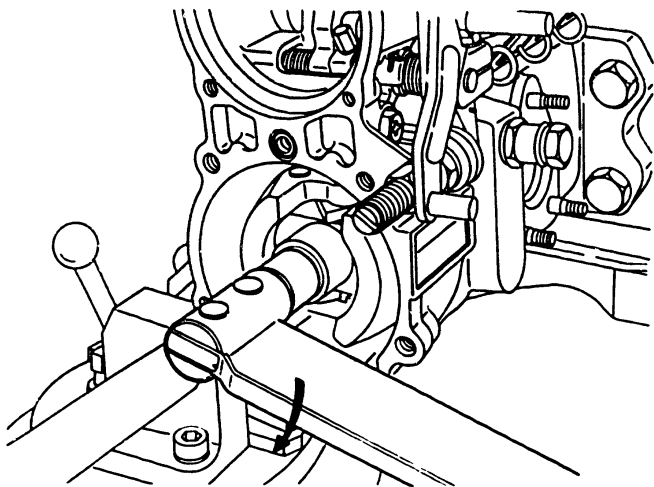

Fig. 49 Tightening the roundnut

Flyweight roundnut

Tighten the flyweight roundnut (122) securely to the specified tightening torque: 5 to 6 kg·m. (Fig. 49)



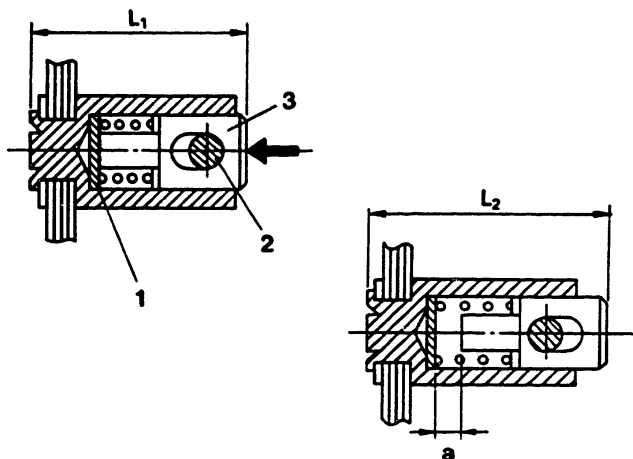

Fig. 50 Rod position measurement

1 = Stroke adjusting shim

2 = Connecting bolt

3 = Rod

a = Torque control stroke

Diaphragm

1. Preadjust the shims as follows to facilitate torque control stroke adjustment.
 - 1) Fit the connecting bolt into the diaphragm.
 - 2) Measure the difference ($L_2 - L_1$) between the pushrod fully inserted and fully extended as shown in Figure 50. The difference is the torque control stroke.



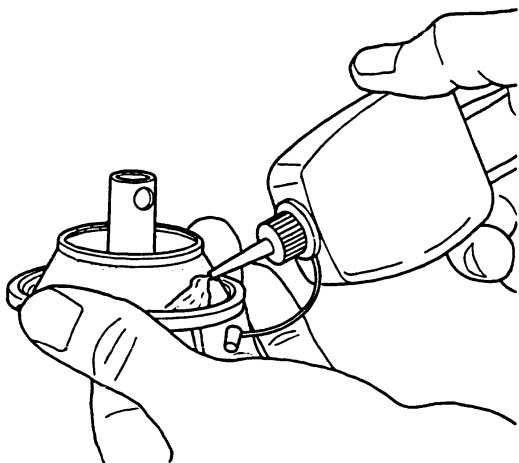

Fig. 51 Applying diaphragm oil

- 3) Adjust shim thickness if the torque-control stroke does not conform to specifications.
2. Apply a sufficient amount of oil to the diaphragm leather. (Fig. 51)



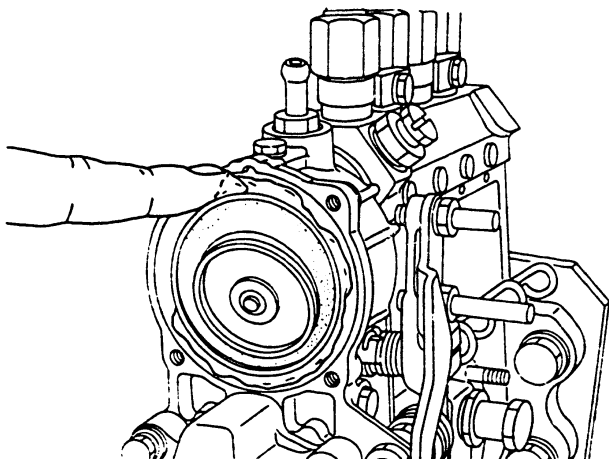

Fig. 52 Applying grease

3. Apply grease to the contact surfaces and caulking of the diaphragm to prevent leakage of air. (Fig. 52)

Note: Be careful not to apply grease to the diaphragm leather.



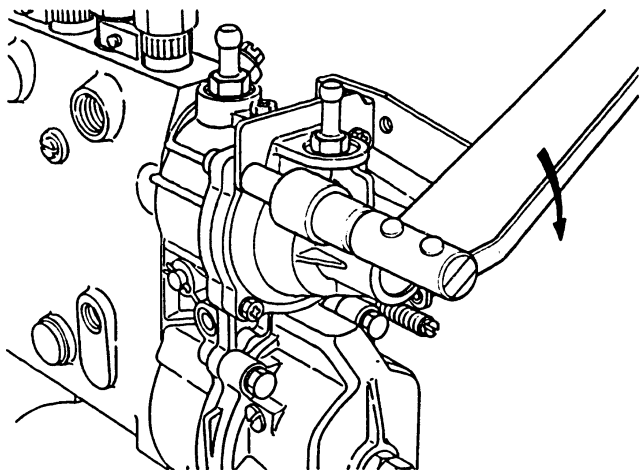

Fig. 53 Tightening the bolts

Diaphragm cover

1. Apply grease to the contact surfaces of the diaphragm.
2. Tighten the four bolts securing the diaphragm cover to a tightening torque of 0.25 to 0.4 kg·m. (Fig. 53)

Note: Be careful not to overtighten the bolts; overtightening can crack the diaphragm cover.



ADJUSTMENT

Perform the following after reassembly of the RBD governor:

1. Pneumatic governor air-tightness test
2. Smoke set-screw adjustment
3. Torque control device adjustment
4. High-speed control adjustment (pneumatic governor)
5. Idling adjustment
6. High-speed control adjustment (mechanical governor)
7. Aneroid compensator adjustment (when installed)

C20

Adjustment
RBD governor



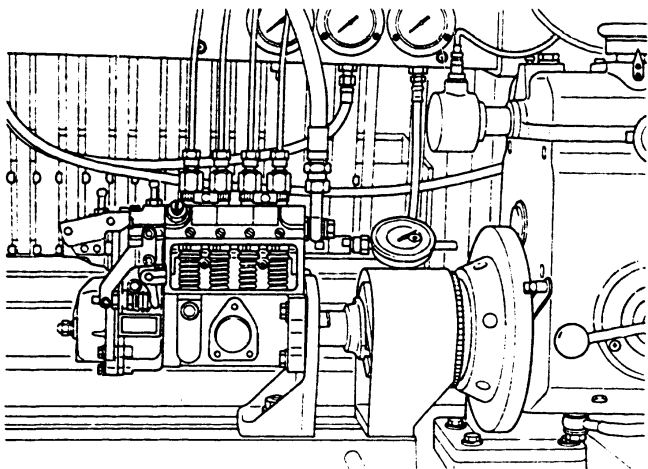

Fig. 54 Mounting injection pump

Preparation

- 1. Mount the fuel injection pump on the pump test stand.**

Attach the test nozzle and nozzle holder assembly, test lines and control rack travel measuring device (1 688 130 130). (Fig. 54)



Preparation (continued)

2. Fill the cam chamber with the specified amount of lubricating oil.
Cam chamber: 20 cc per cylinder.
3. Remove plug (23), loosen the idling spring capsule about three turns using a wrench (KDEP 2657) and screwdriver, and then temporarily fix locknut (21).

G22

Adjustment
RBD governor



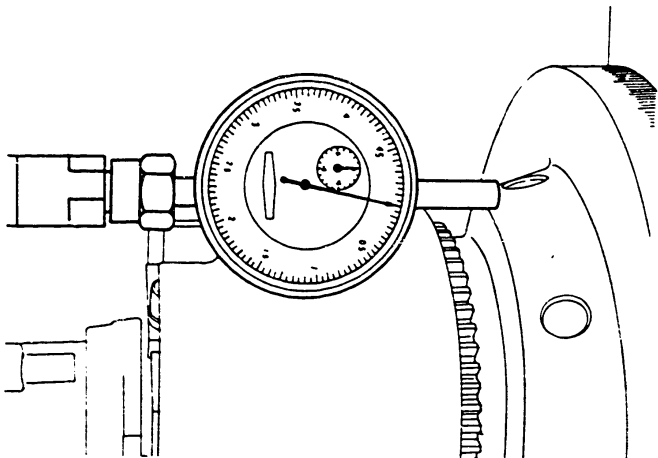

Fig. 55 Setting "zero" point

4. Setting the "zero" position of the control rack

Find the control rack's "zero" position by pushing the control pinion towards the drive side with a screwdriver to move the control rack towards the governor side.

The position where the control rack stops is the control rack's "zero" position.

Then, set the dial gauge to "zero". (Fig. 55)



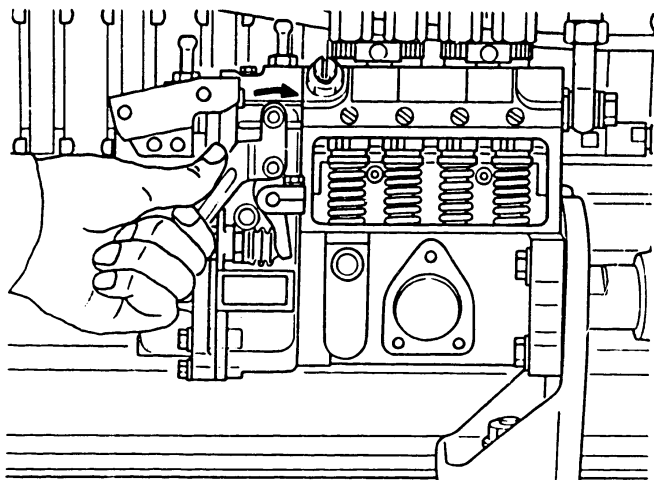

Fig. 56 Confirmation of the control rack stroke

5. Confirmation of control rack stroke

Push the control lever fully in the "fuel-increase" direction to check that the control rack moves 15 mm or more. If not, replace the pushrod with a shorter one. (Figs. 56 and 57)



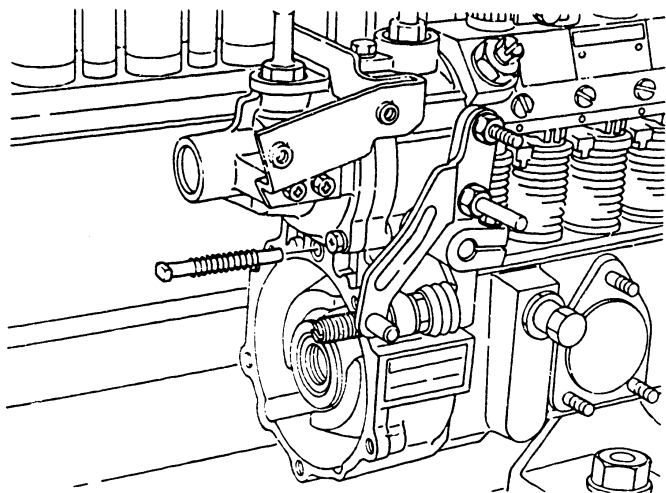

Fig. 57 Pushrod replacement

6. Connect a vinyl hose between the vacuum pump on the pump test stand and the negative pressure chamber of the governor.

Note: Ensure tight connections.

If the connections are not tight air will leak, resulting in limited negative pressurization.

7. Always drive the injection pump at 500 rpm to measure pneumatic governor performance.



Pushrods

* Part No.	Length (mm)
155411-0200	51
155411-0300	51.5
155411-0400	52
155411-7800	48.5
155411-7900	49.5
155411-8000	50.5
155411-9700	48
155411-9800	49
155411-9900	50

* Bosch Nr., see cross reference DKKC - Bosch, microfiche HB 30, HB 31

C26

Adjustment
RBD governor



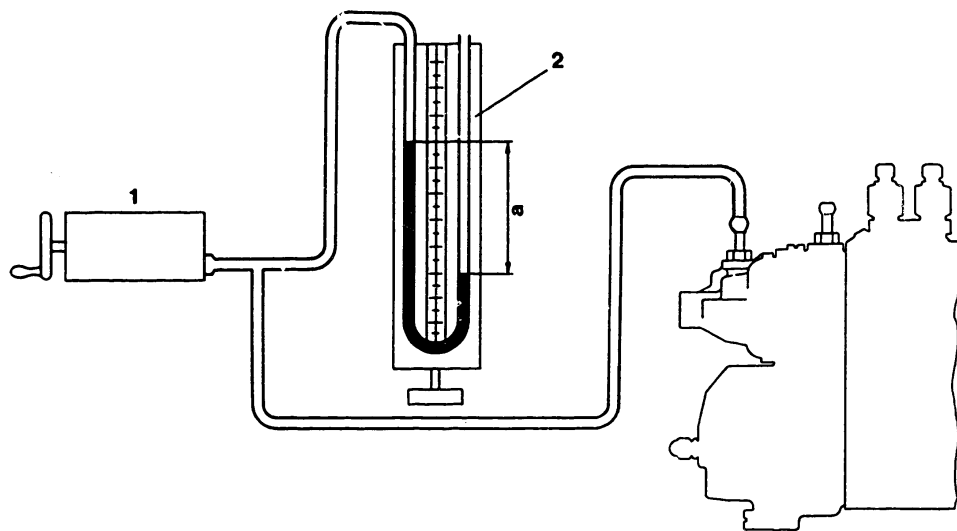

Fig. 58

Air-Tightness Test

- 1 = Vacuum pump
- 2 = Negative pressure gauge
- a = 500 mmAq

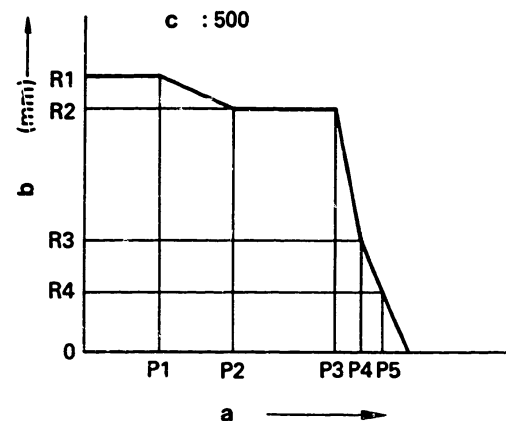

Fig. 59 Pneumatic governor performance

- a = Negative pressure (mmAq)
- b = Control rack position
- c = Pump speed: 500 rpm

1. Reduce pressure of the pneumatic governor's negative pressure chamber to A (500 mmAq) at pump speed of 500 rpm and control rack position R1. (Figs. 58 and 59)
2. Ensure it takes ten seconds or more for negative pressure to fall from level A (500 mmAq) to level B. If it takes less than ten seconds check diaphragm assembly. Replace the diaphragm if interval is still less than 10 seconds.

G27

Adjustment
RBD governor

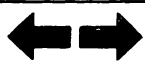

C28

Adjustment
RBD governor



Diaphragm dia. (ϕ mm)	Negative pressure (mmAq)	
	A	B
60	500	480
80	500	400

D1

Adjustment

FBD governor



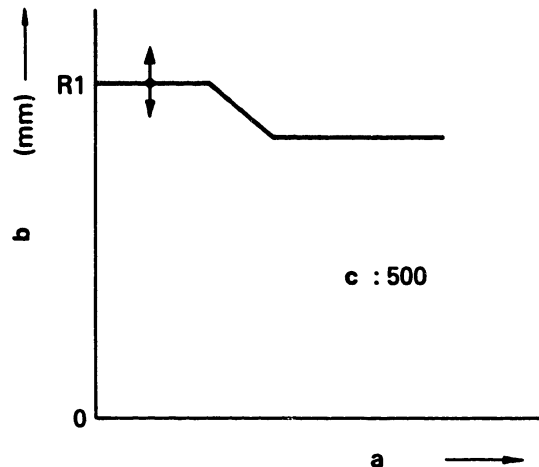

Fig. 60

a = Negative pressure (mmAq)
 b = Control rack position
 c = Pump speed: 500 rpm

Smoke Setscrew Adjustment

1. Remove the vinyl hose from the negative pressure chamber of the governor.
2. Adjust the smoke setscrew so that the control rack can be positioned at R1, and then fix it using the nut. (Figs. 60 and 61)

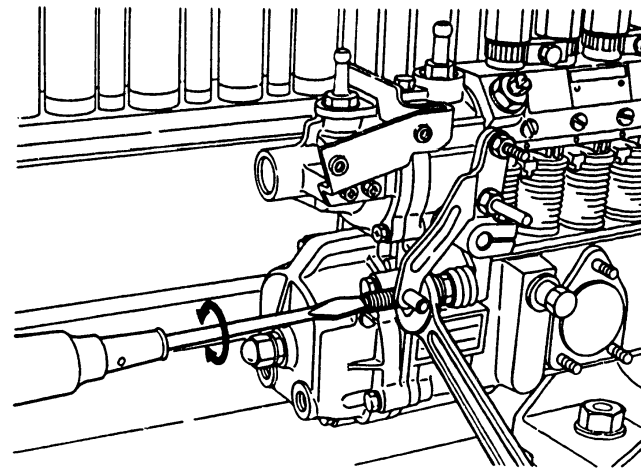

Fig. 61 Adjusting the smoke setscrew

D2

Adjustment
 RBD governor



D3

Adjustment
 RBD governor



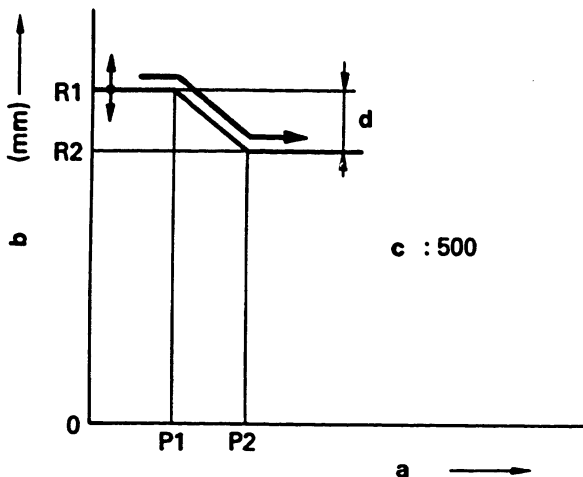

Fig. 62

a = Negative pressure (mmAq)

b = Control rack position

c = Pump speed: 500 rpm

d = Torque-control stroke

Torque-Control Adjustment

1. Connect a vinyl hose from the vacuum pump to the negative pressure chamber of the governor.
2. Gradually decrease pressure until torque-control stroke equals $(R1-R2)$.



Torque-Control Adjustment (continued)

If torque-control stroke does not conform to specifications, adjust the thickness of the shim by detaching the diaphragm. If the torque-control stroke is too small, replace the shim with a thinner one. Since rack control position R1 varies with shim thickness, readjust the smoke setscrew. (Fig. 62)

Adjusting shims

* Part No.	Diameter (mm)	Thickness (mm)
155407-2100		0.2
155407-2200		0.3
155407-2300		0.5
155407-2400		1.0
155407-2500		0.1
155407-2600		0.15
155407-2700		0.15

* Bosch Nr., see cross reference DKKC - Bosch, microfiche HB 30, HB 31



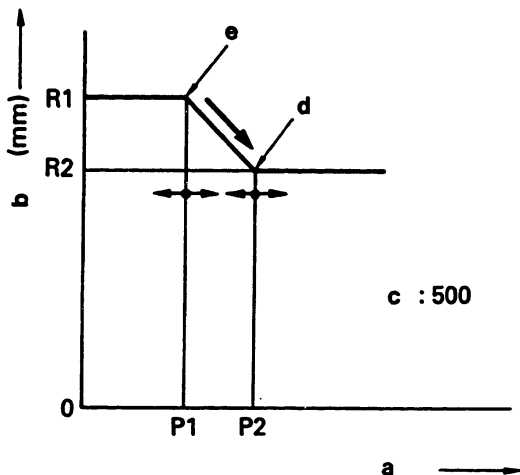

Fig. 63

- a = Negative pressure (mmAq)
- b = Control rack position
- c = Pump speed: 500 rpm
- d = End of torque-control spring movement
- e = Start of torque-control spring movement

3. Increase pressure and then decrease gradually to check that at P_1 the control rack will begin to move from R_1 in the "fuel-decrease" direction, and then stop at P_2 . If the result does not conform to specifications, adjust shim thickness by detaching the diaphragm. (Fig. 63)



If pressure levels P_1 and P_2 are too low,
replace the shim with a thicker one.

Adjusting shims

* Part No.	Diameter (mm)	Thickness (mm)
029310-5030		0.2
029310-5040		0.3
029310-5050		0.5
029310-5060		1.0
029310-5180		0.1
029310-5210		0.15
029310-5220		0.25

* Bosch Nr., see cross reference DKKC - Bosch,
HB 30, HB 31.

D7

Adjustment

RBD governor



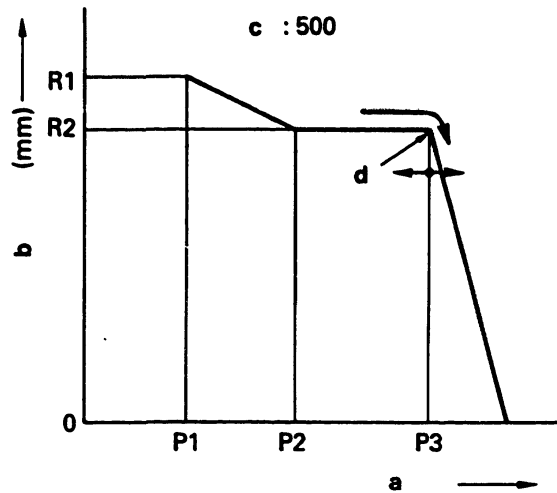

Fig. 64

- a = Negative pressure (mmAq)
- b = Control rack position
- c = Pump speed: 500 rpm
- d = Governor spring set point

High-Speed Control Adjustment (Pneumatic Governor)

Adjust the governor spring (11) setting force by changing shim thickness so that at negative pressure level P₃ the control rack begins to move from R₂ in the "fuel-decrease" direction. (Figs. 64 and 65)

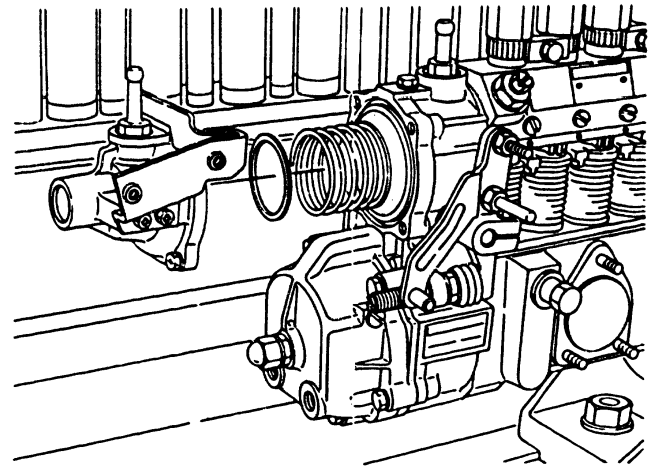

Fig. 65 Adjusting shim replacement

D8

Adjustment
RBD governor



D9

Adjustment
RBD governor



- Notes: 1. If the total thickness of the shims is 5.0 mm or more replace the governor spring, since in this state the governor spring will detach from the diaphragm cover's spring seat.
2. After shim adjustment check the torque control spring for negative pressure range operation.

Adjusting shims

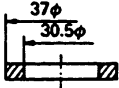
* Part No.	Diameter (mm)	Thickness (mm)
155407-1100		0.5
155407-1200		1.0
155407-1300		1.5
155407-1400		2.0
155407-1500		2.5
155407-1600		3.0
155407-1700		0.2
155407-1800	0.3	

* Bosch Nr., see cross reference DKKC - Bosch, microfiche HB 30, HB 31.

D10

Adjustment

RBD governor



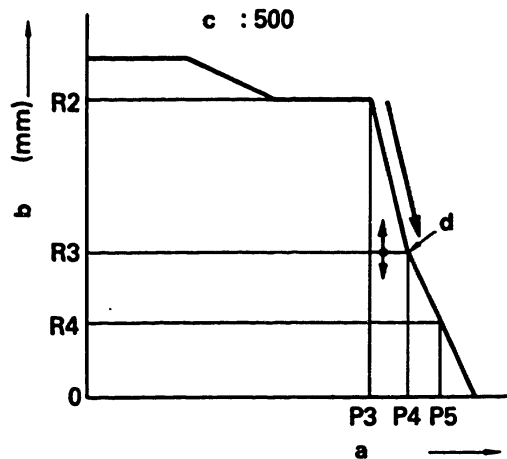

Fig. 66

- a = Negative pressure (mmAq)
- b = Control rack position
- c = Pump speed: 500 rpm
- d = Idling spring set point

Idling Adjustment

1. Maintaining negative pressure at P_4 , fit the idling spring capsule (18) and fix the control rack in position R_3 using locknut (21). (Figs. 66 and 67)
2. Apply further pressure and check that the negative pressure becomes P_5 when the control rack is in position R_4 . If the result does not conform to specifications, replace the idling spring capsule.

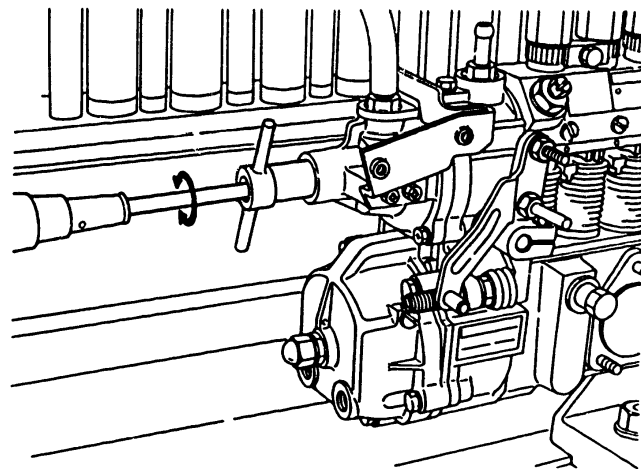

Fig. 67 Idling spring capsule adjustment

D11

Adjustment
RBD governor



D12

Adjustment
RBD governor



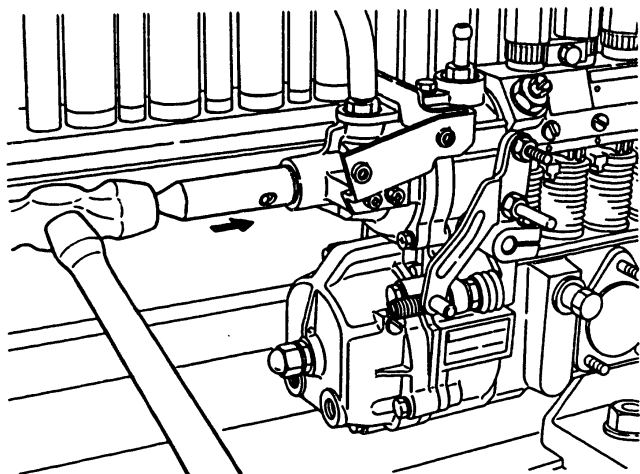

Fig. 68 Press-fitting the plug

3. Press-fit the plug into the diaphragm cover.
(Fig. 68)

Note: Apply adhesive to the plug in order to prevent air leaks or the plug from detaching.



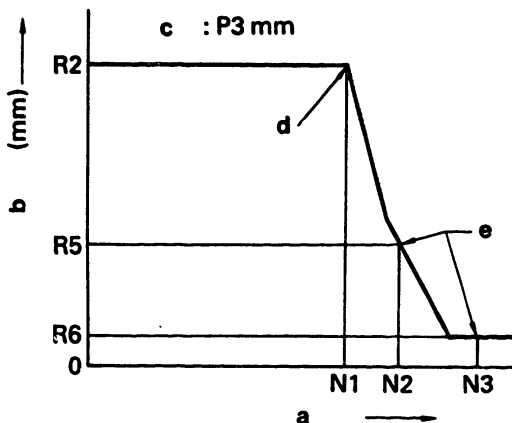

Fig. 69

- a = Pump speed (rpm)
- b = Control rack position
- c = Negative pressure: P3 mmAq
- d = Governor spring set point
- e = Check point

Maximum-Speed Control Adjustment (Mechanical Governor)

1. Perform this adjustment with negative pressure maintained at P₃. (Fig. 69)



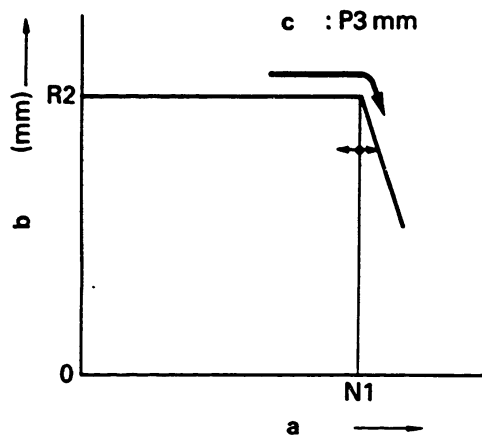

Fig. 70

a = Pump speed (rpm)
 b = Control rack position
 c = Negative pressure: P3 mmAq

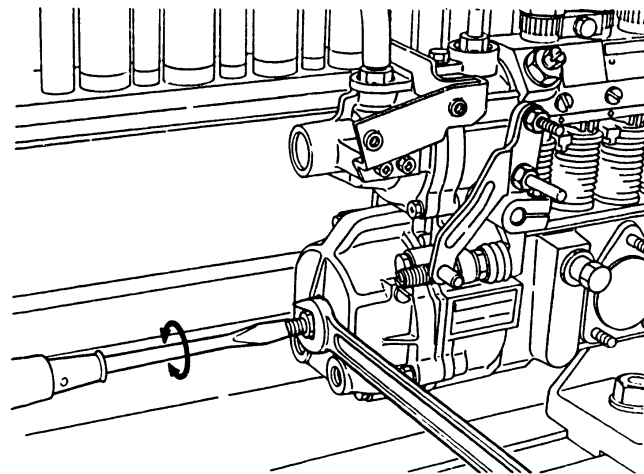

Fig. 71 Beginning of maximum-speed control adjustment

2. Increase pump speed and adjust adjusting bolt (130) so that the control rack begins to move from R_2 in "fuel-decrease" direction. (Figs. 70 and 71)

D15

Adjustment
 RBD governor



D16

Adjustment
 RBD governor



Note: If the adjusting bolt does not cover the entire adjustment range change the thickness of adjusting shim (130) between spring seat (126) and governor spring (128).

Adjusting shims

* Part No.	Diameter (mm)		Thickness (mm)
	Outside	Inside	
029302-3010	30 ϕ	23 ϕ	0.5
029302-3020	30 ϕ	23 ϕ	1.0
029302-5000	30 ϕ	25 ϕ	0.5
029302-5010	30 ϕ	25 ϕ	1.0

* Bosch Nr., see cross reference DKKC - Bosch, microfiche HB 30, HB 31.

D17

Adjustment
RBD governor



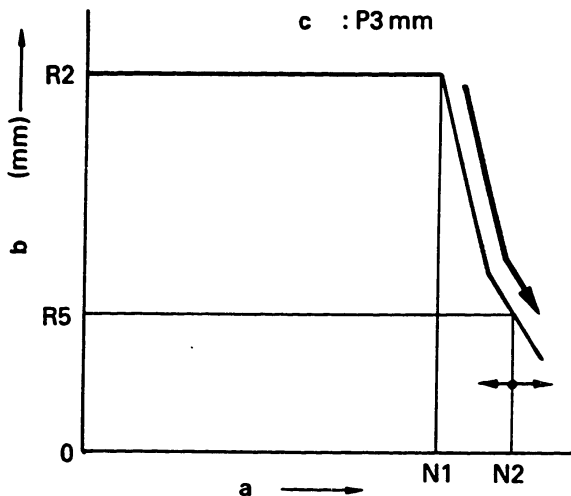

Fig. 72

- a = Pump speed (rpm)
- b = Control rack position
- c = Negative pressure: P3 mmAq

3. Increase pump speed and check that the pump speed at control rack position R₅ is N₂. (Fig. 72)

Note: If the pump speed does not conform to specifications, replace the governor spring and readjust pump speed.



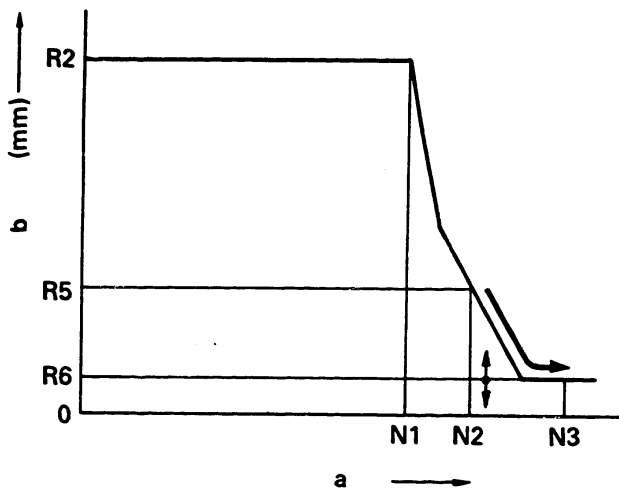

Fig. 73

a = Pump speed (rpm)
 b = Control rack position

- Further increase pump speed and check that the control rack is positioned at R_6 when the pump speed is N_3 . (Fig. 73)



Note: If the control rack does not reach R₆, check the components between the flyweights and the pushrod for wear, and the pump camshaft for deviation toward the drive side.

If there is no problem with these parts, adjust the length of the pushrod (111) to the required value. (See page 25 for pushrod length and Part No.)

Replace pushrod (111) if necessary.

After the above adjustment seal each stopper.

D20

Adjustment

RBD governor



Aneroid Compensator Adjustment (When installed)

Install and adjust the aneroid compensator after adjustment of the RBD governor.
The figures in parentheses indicate the key numbers in Fig. 17.

Caution: The aneroid compensator must be adjusted at sea level.

021

Adjustment

RBD governor



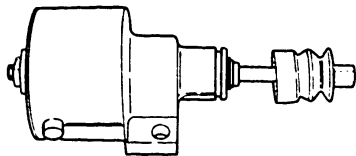

Fig. 74 Rubber boot removal

- 1. Remove the aneroid compensator rubber boot (170/12) from the housing. (Fig. 74)**



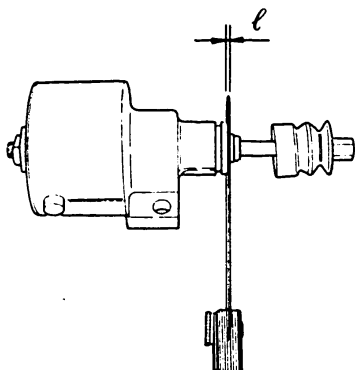

Fig. 75 Gap (ℓ) measurement

2. Ensure the gap between the housing and snap-ring is as specified in the Service Data. (Fig. 75)

Note: Unless the Service Data contains the specified value for gap (ℓ), use the following value:

$$\ell = 0.5 \text{ to } 0.7 \text{ mm}$$



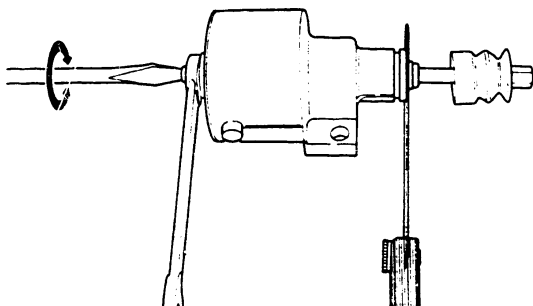

Fig. 76 Setting screw placement

3. If the gap does not comply with the standard value, adjust using the setting screw (170/7) and fix the nut (170/8).

D24

Adjustment
RBD governor



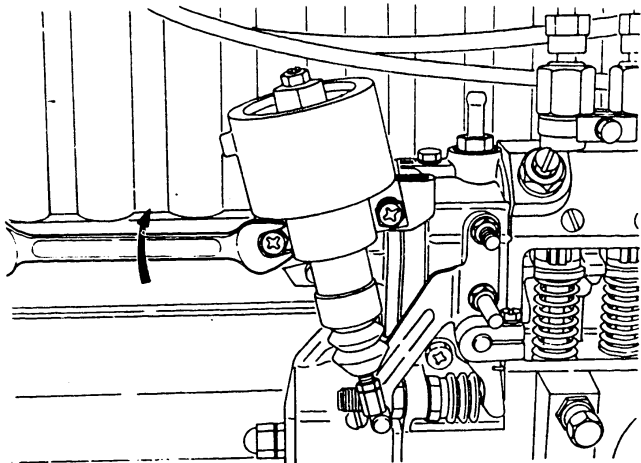

Fig. 77 Aneroid compensator assembly installation

4. Attach the aneroid compensator assembly to the bracket (33) using two bolts (171).



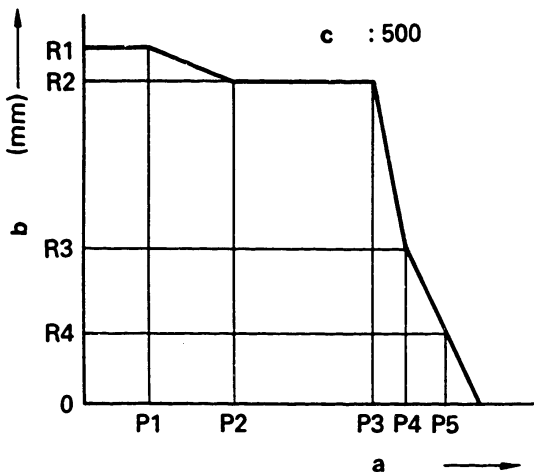

Fig. 78 Pneumatic governor performance

- a = Negative pressure (mmAq)
 b = Control rack position
 c = Pump speed: 500 rpm

5. Maintain pump speed at 500 rpm after adjustment of the RBD governor.
6. Ensure that the control rack positions R1 and R2 are secured by decreasing pressure of the pneumatic governor gradually from 0. (Fig. 78)



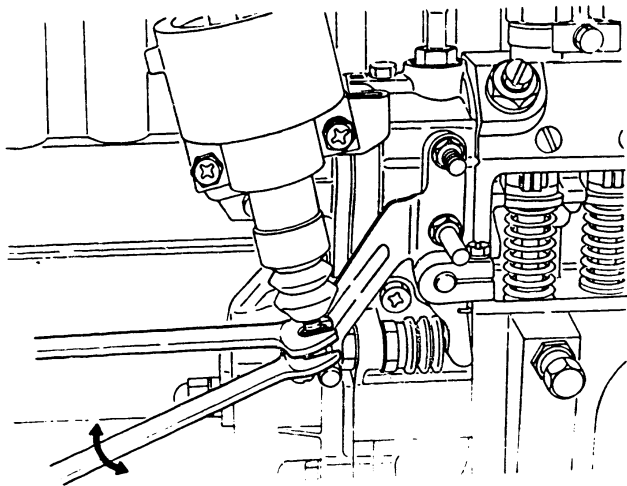

Fig. 79 Temporary adjustment of cap

7. Loosen the nut (170/16).
8. Loosen the cap and then screw in until it just contacts the control lever pin. (Fig. 79)

D27

Adjustment
RBD governor



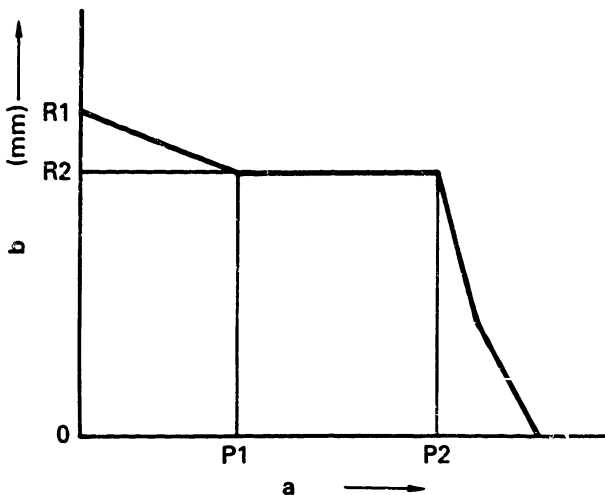

Fig. 80

a = Negative pressure (mmAq)

b = Control rack position

9. Cap setting

-1. When the performance of the pneumatic governor is as shown in Fig. 80:

- a. Maintain pump speed at 500 rpm and reduce the pressure of the pneumatic governor's negative pressure chamber to P_2 mmAq (Fig. 80).



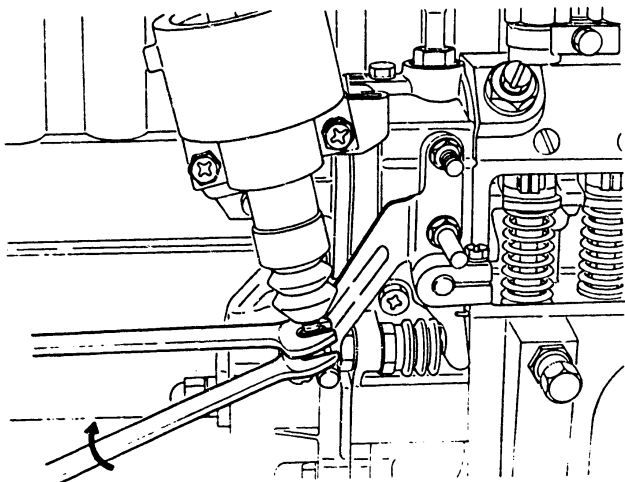

Fig. 81 Cap adjustment

- b. Adjust the cap so that the control rack moves 0.01 to 0.05 mm from position R2 in the "fuel-decrease" direction, and secure with the nut. (Figs. 80 and 81)

E1

Adjustment
RBD governor



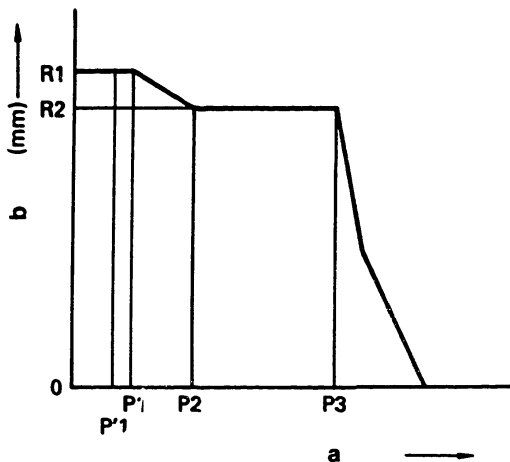

Fig. 82

a = Negative pressure (mmAq)
 b = Control rack position

- 2. When the performance of the pneumatic governor is as shown in Fig. 82:
 - a. Maintain pump speed at 1,000 rpm and reduce the pressure of the pneumatic governor's negative pressure chamber to $P'1$ mmAq (Fig. 82).
 - b. Adjust the cap so that the control rack moves 0.01 to 0.05 mm from position $R1$ in the "fuel-decrease" direction and secure with the nut. (Figs. 81 and 82)

E2

Adjustment
 RBD governor



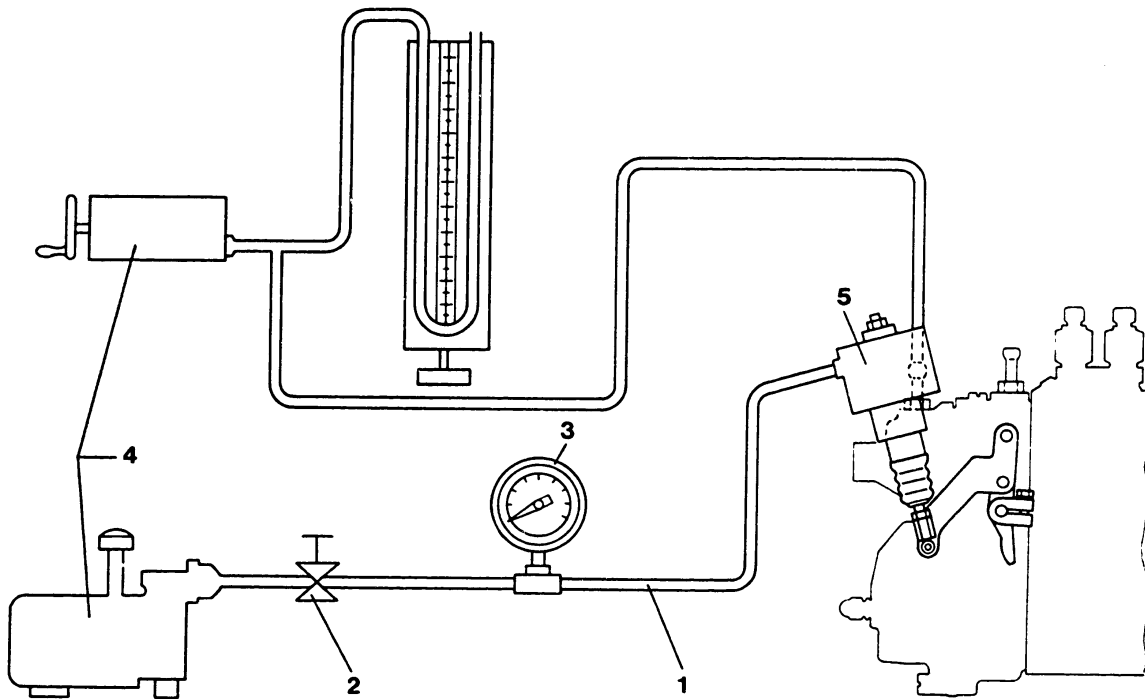

Fig. 83 Aneroid compensator adjustment piping

- 1 = Rubber tube
- 2 = Regulating valve
- 3 = Pressure gauge
- 4 = Vacuum pump
- 5 = Aneroid compensator

10. Checking aneroid compensator performance

-1. Piping should be as shown in Fig. 83.

E3	Adjustment	↔
	RBD governor	

E4	Adjustment	↔
	RBD governor	

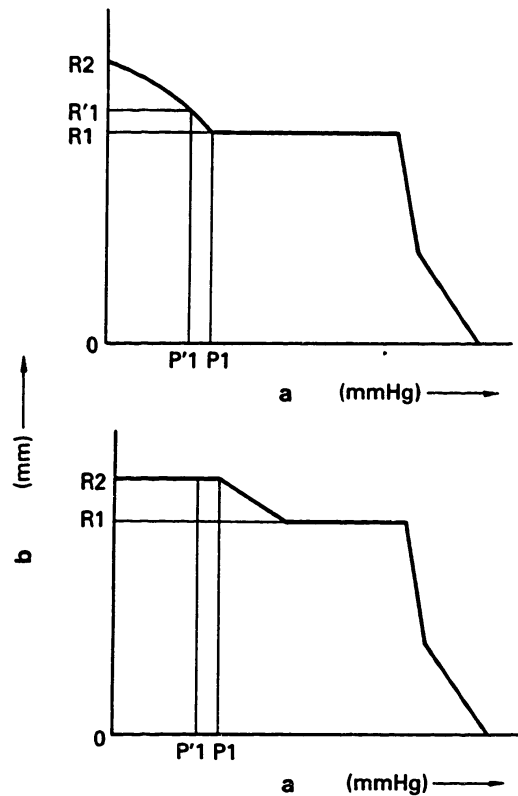

Fig. 84

a = Negative pressure
b = Control rack position

-2. Maintain the pump speed indicated in the Service Data (usually 1,000 or 1,100 rpm) and reduce the pressure of the pneumatic governor's negative pressure chamber to P'1 mmAq. (Fig. 84)

E5

Adjustment
RBD governor



E6

Adjustment
RBD governor



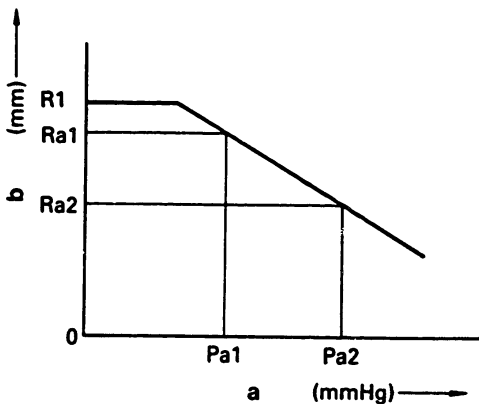

Fig. 85 Aneroid compensator performance

a = Negative pressure
 b = Control rack position

- 3. Ensure the control rack moves to the positions $Ra1$ and $Ra2$ when the aneroid compensator pressure is reduced to $Pa1$ and $Pa2$ respectively. (Fig. 85)



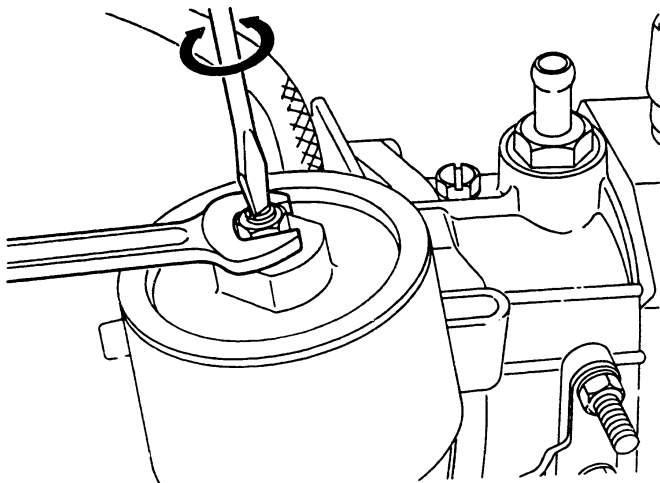

Fig. 86 Setting screw adjustment

- 4. Readjust the setting screw (170/7) if the performance of the aneroid compensator is not as specified.

E8

Adjustment
RBD governor



11. After adjusting the aneroid compensator, measure the fuel injection quantity when the control rack is positioned at R2 mm as shown in Fig. 84, when the aneroid compensator is not operating. If the fuel injection quantity is not as specified, readjust the aneroid compensator.

Note: Refer to Service Data for specified values, pump speed and pneumatic governor negative pressure chamber pressure.

E9

Adjustment

RBD governor



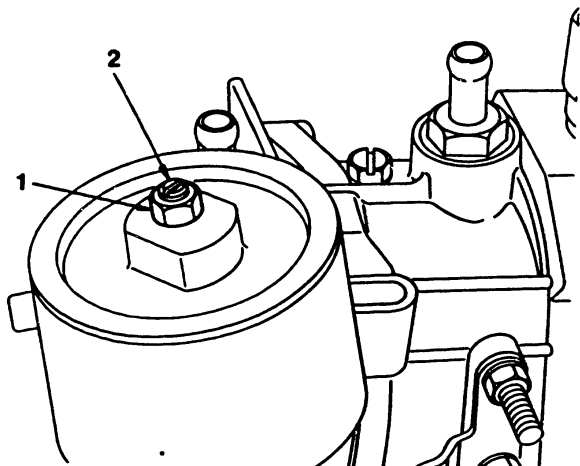

Fig. 87 Setting screw and nut

- 1 = Nut
- 2 = Setting screw

12. Attach the rubber boot to the housing.
13. Paint the setting screw and nut red.

Aneroid compensator sea level adjustment is now complete.



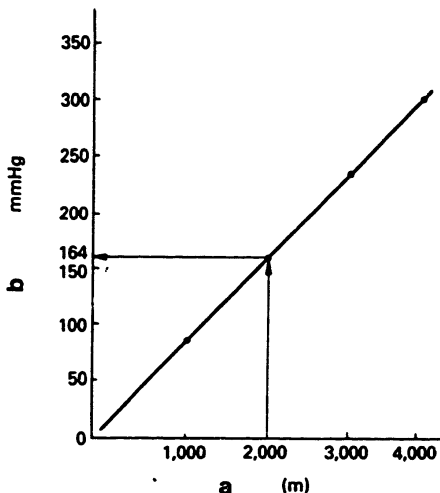

Fig. 88

a = Altitude

b = Atmospheric pressure (Negative pressure)

Aneroid compensator adjustment at high altitudes (for reference only)

1. Because the specified values are not prepared for each altitude, obtain the negative pressure by plotting it from the appropriate altitude in Fig. 88. For example, the atmospheric pressure at an altitude of 2,000 m is 164 mmHg of negative pressure.



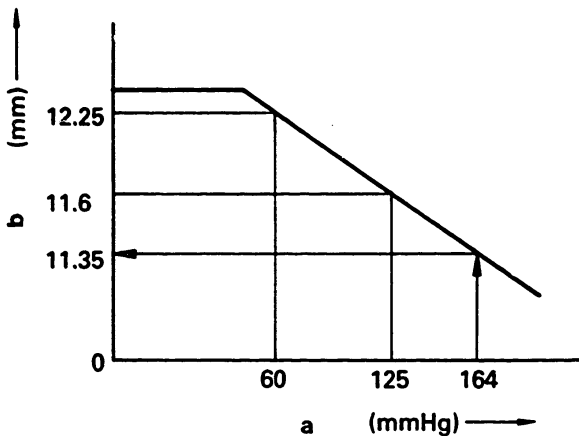

Fig. 89

a = Negative pressure
 b = Control rack position

2. Obtain the control rack position value in accordance with the negative pressure plotted from the Service Data. In Fig. 89 for example, the control rack position value corresponding to a negative pressure of 164 mmHg is 11.35 mm.



3. Then divide the value obtained from Fig. 89 by the corrected value of 1.17, to obtain the actual control rack position corresponding to the altitude.

e.g.

The control rack position at an altitude of 2,000 m described previously is:

$$\frac{11.35}{1.17} = 9.7 \text{ mm}$$



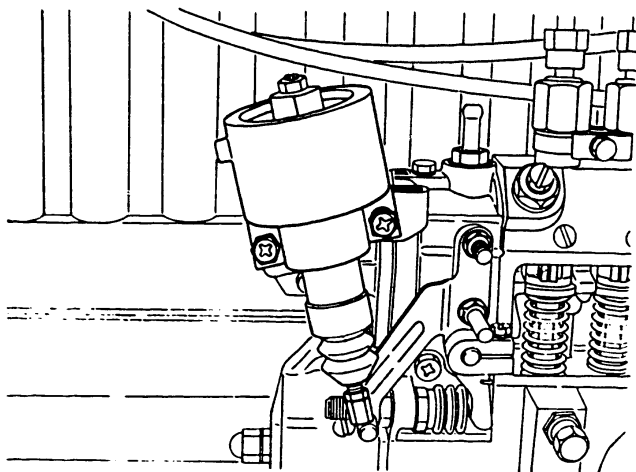

Fig. 90 Attaching the aneroid compensator

- 4. Attach the aneroid compensator to the bracket.
(Fig. 90)**



5. Maintain the pump speed specified in the Service Data (usually 1,000 or 1,100 rpm) and reduce the pneumatic governor's negative pressure chamber pressure to P'1 mmAg (see Fig. 84).

Note: The piping for the aneroid compensator shown in Fig. 83 is not required.

E15

Adjustment

RBD governor



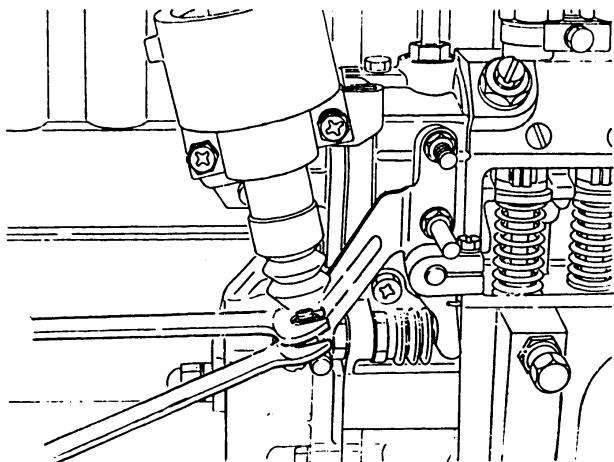

Fig. 91 Adjusting the cap

6. Adjust the control rack using the cap if it is not positioned as indicated in Step 3. (Fig. 91)

Note: Never adjust the setting screw.



HANDLING PRECAUTIONS

Lubricating oil

Injection pump oil

Lubricating oil is supplied to the governor chamber from the cam chamber by the impeller:

1. For injection pumps where engine oil circulates within the cam chamber, check and replace the engine oil at the intervals specified by the engine maker.
2. For injection pumps where no engine oil is fed to the cam chamber, check, replenish and replace the lubricating oil at the following intervals:

Inspection and replenishment:
50 hours (or 1000 km)

Replacement:
200 hours (or 4000 km)



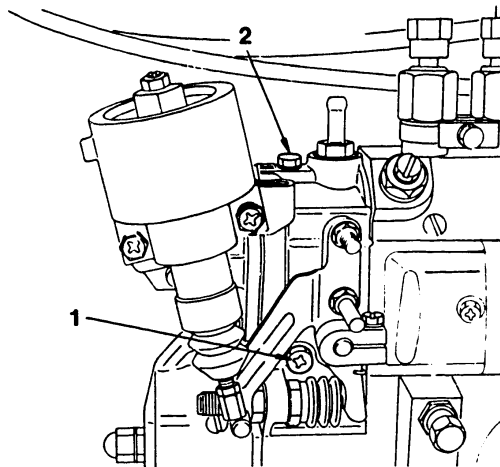

Fig. 92 Drain plug and filler plug

- 1 = Drain plug
- 2 = Filler plug

Diaphragm oil

Drain used oil through the drain plug and pour 4 - 5 cc of oil onto the diaphragm blades through the filler plug at intervals of 200 hours, or 4000 km. (Figs. 92 and 93)

Note:

The control lever should be moved in the "fuel-increase" direction to position the diaphragm under the filler plug.

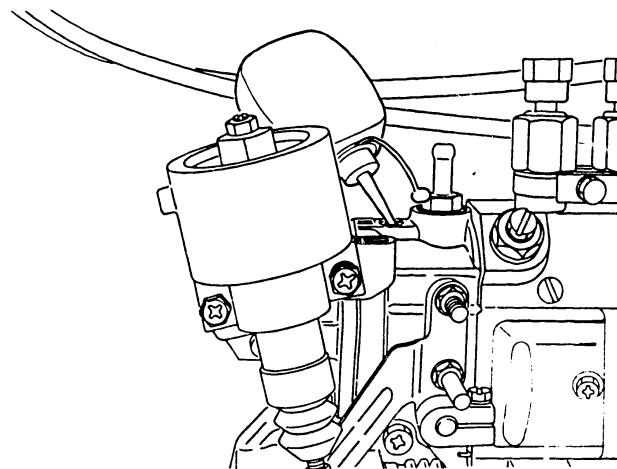

Fig. 93 Diaphragm lubrication

E18

Handling precautions
RBD governor



E19

Handling precautions
RBD governors



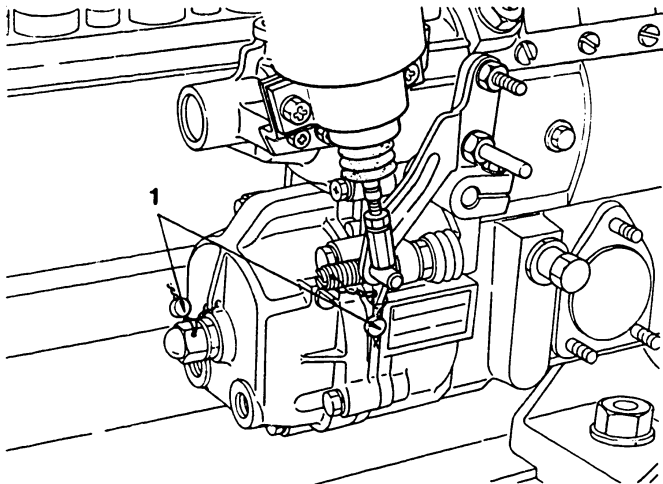

Fig. 94 Seals

1 = Seal

Sealing

Each governor stopper is adjusted and sealed on a pump test stand or engine test bench. Do not unseal or readjust unless the above equipment is available. (Fig. 94)

E20

Handling precautions
RBD governor



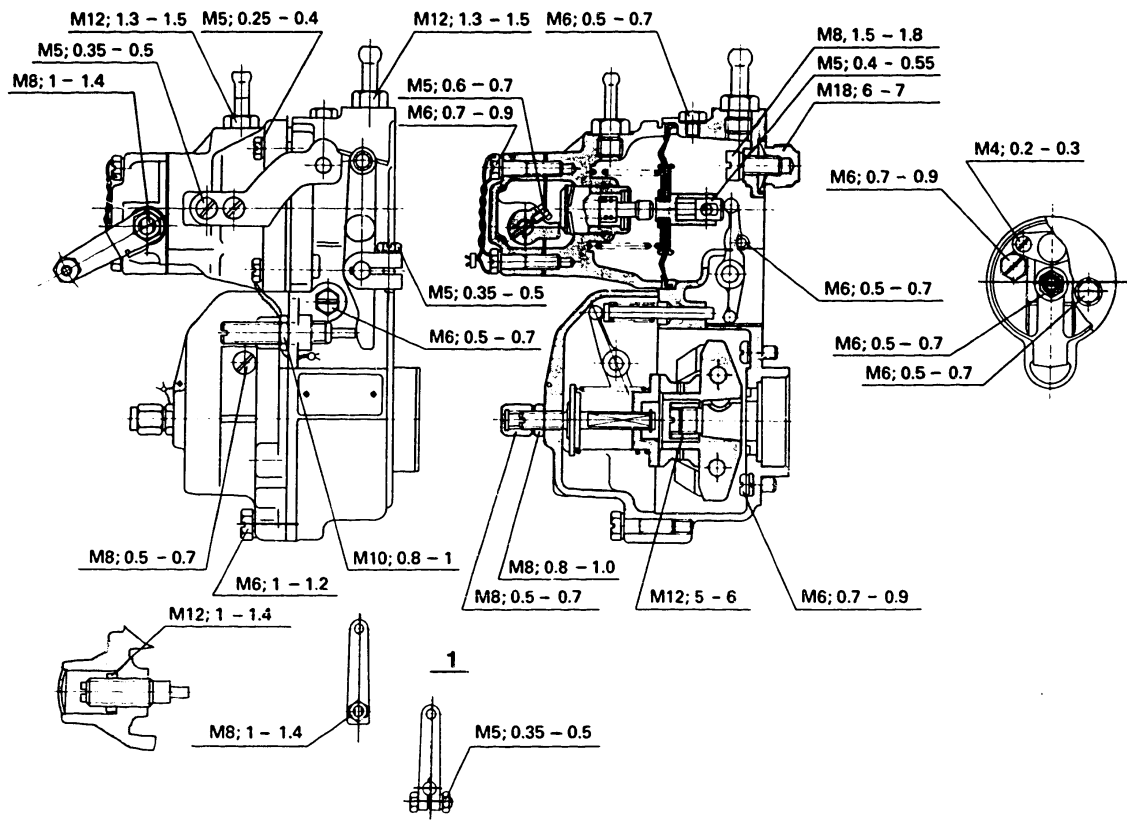



Fig. 95

1 = Control lever

Unit: kg.m

TIGHTENING TORQUE

E21	Tightening torque	
	RBD governor	

E22	Tightening torque	
	RBD governor	

EXPLANATION OF PART NUMBER

Code Number

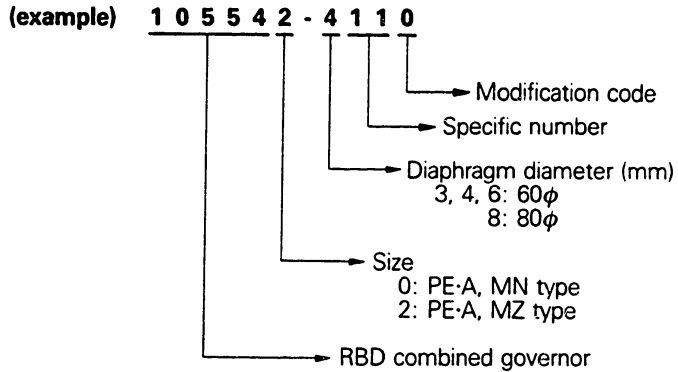

Bosch Type Number

(example) **NP - EP / RBD 2100 A Z 4 / Y L**
(1) (2) (3) (4) (5) (6) (7) (8) (9)

- (1) Manufactured by DIESEL KIKI CO. LTD.
- (2) For injection pump
- (3) RBD model combined governor
- (4) Controlled maximum speed (rpm)
- (5) Injection pump size
- (6) N: MN type
Z: MZ type

E23

Explanation of part number
RBD governor

**E24**

Explanation of part number
RBD governor



Explanation of part number (continued)

(7)

	Weight of flyweight	Rotational direction viewed from pump drive side
1	270g	Counterclockwise rotation
2	270g	Clockwise rotation
3	215g	Counterclockwise rotation
4	215g	Clockwise rotation

(8) S: Without torque control device

C: With torque control device

Y: With aneroid compensator

(9) Installation position

R: Pump fitted at right side

L: Pump fitted at left side

E25

Explanation of part number

RBD governor



E26

Explanation of part number

RBD governor



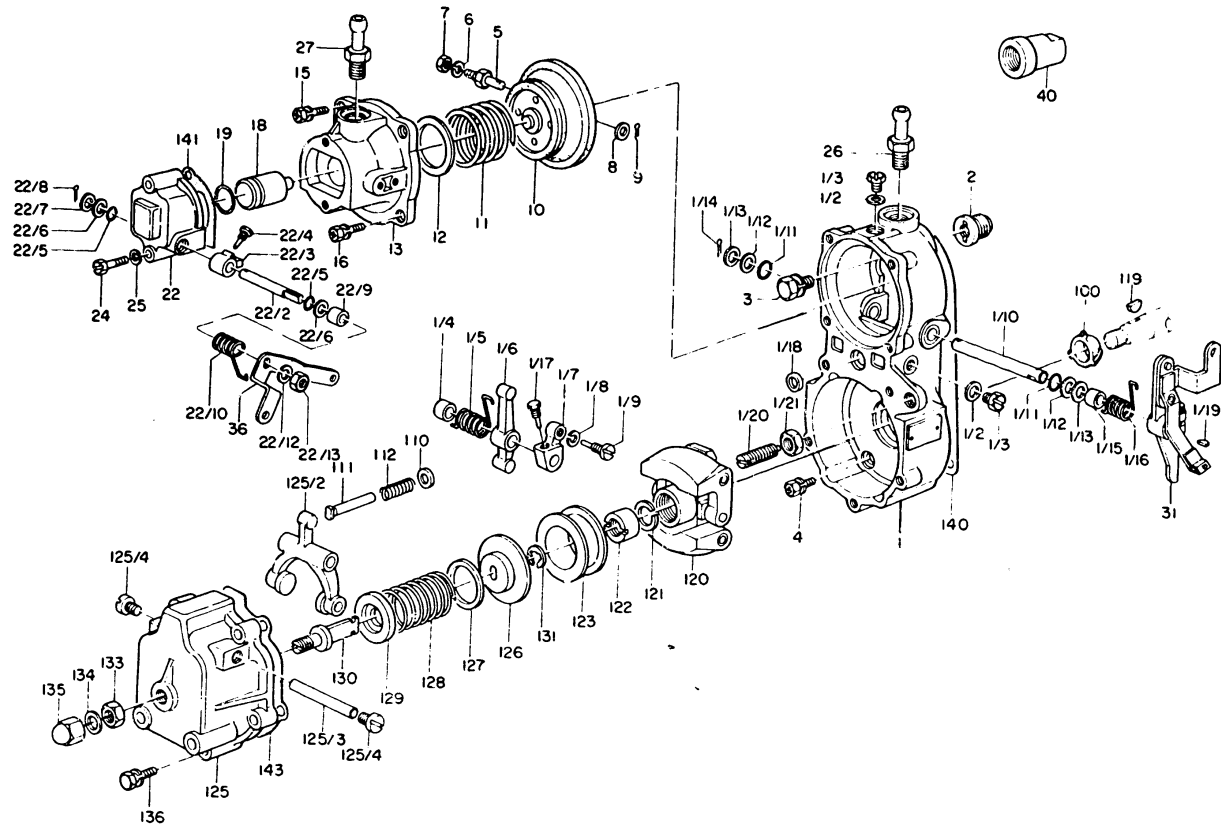



Fig. 96

EXPLODED VIEW OF RBD GOVERNOR (MN TYPE)

E27	Exploded view	
	RBD governor	

E28	Exploded view	
	RBD governor	

CONTENTS

	Coordinate
FEATURES	A 2
CONSTRUCTION	A 7
OPERATION	A 12
Control of Engine Starting	A 12
Idling Control	A 15
Normal Operating Conditions	A 16
Maximum-Speed Control	A 17
Torque Control Device	A 18
ANEROID COMPENSATOR	A 24
Construction and Operation	B 3
DISASSEMBLY	B 11
Preparation	B 11
INSPECTION	C 5
REASSEMBLY	C 12
ADJUSTMENT	C 20
Preparation	C 21
Air-tightness Test	C 27
Smoke Setscrew Adjustment	D 2
Torque Control Adjustment	D 4
High-Speed Control Adjustment (Pneumatic Governor)	D 8
Idling Adjustment	D 11
Maximum Speed Control Adjustment (Mechanical Governor)	D 14
Aneroid Compensator Adjustment	D 21

N25

Contents
RBD governor



N26

Contents
RBD governor



CONTENTS (continued)

Coordinate

HANDLING PRECAUTIONS	E 17
TIGHTENING TORQUE	E 21
EXPLANATION OF PART NUMBERS	E 23
EXPLODED VIEW OF RBD GOVERNOR (MN TYPE)	E 27